

## NAXOS LT 50

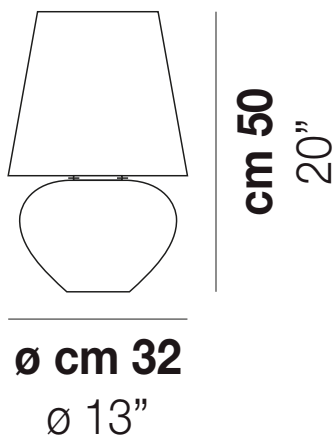

### DATI TECNICI:

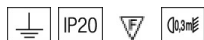

### CERTIFICAZIONI:



### SORGENTI LUMINOSE

E27	1x77w	220-240V 50/60 Hz	INCANDESCENTE
+	1x40w	220-240V 50/60 Hz	INCANDESCENTE

VOLUME	Mc 0,17
PESO LORDO	Kg 7,1
PESO NETTO	Kg 3,8

download risorse



### FINITURA DEL DIFFUSORE



BC/ST

### FINITURA MONTATURA



BC

### ALTRE VERSIONI DISPONIBILI

clicca sul disegno per accedere alla pagina web della relativa product sheet



NAXOS LT 33

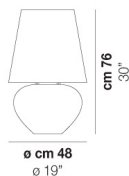

NAXOS LT 76



NAXOS LT MN