

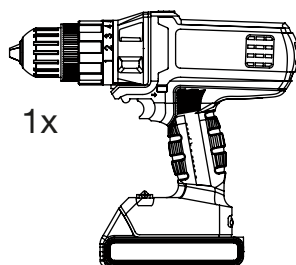

Vetzeria Vistosi Srl · Via G. Galilei, 9-9/A-11 · 31021 Mogliano V.to · Treviso · Italy  
 P. Iva IT02497840278 · Cap. Soc. € 100.000,00 I.V. · N° R.E.A. TV - 170728  
 Cod. Fisc. - R.I. N° 01808840266 · Iscr. Reg. AEE N° IT08010000000170  
 Tel. +39 041 5900170 - 041 5903480 · Fax +39 041 5900992 - 041 5904540  
 vetrieriavistosi@legalmail.it · www.vistosi.it · vistosi@vistosi.it

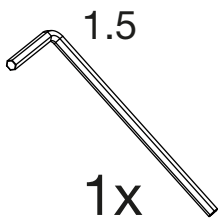

## Tools - Attrezzi

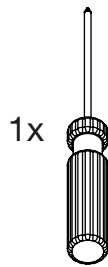
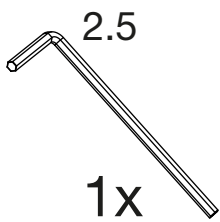



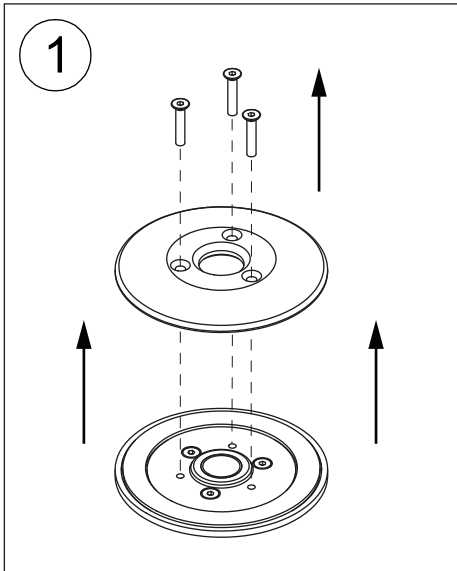
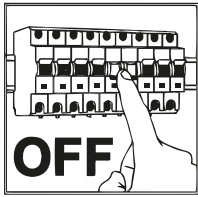

## Step 1

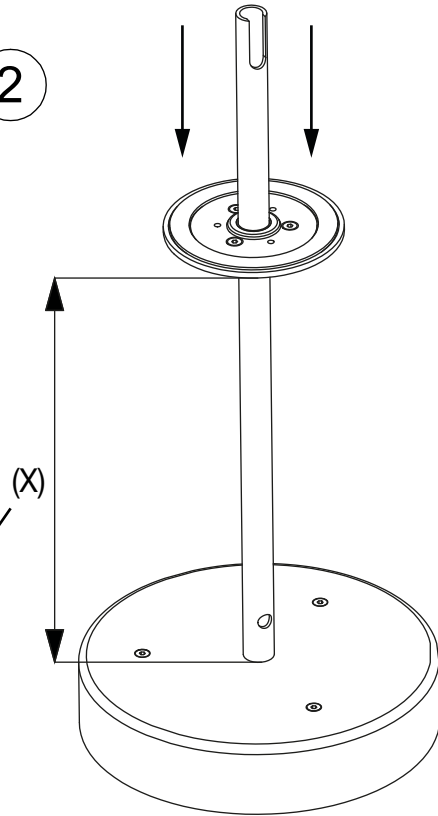

2

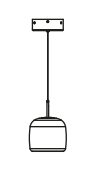

	<b>Jube SP G</b> X=100mm (4 INCHES)
	<b>Jube SP 1G</b> X=90mm (3.5 INCHES)
	<b>Jube SP P</b> X=185mm (7.2 INCHES)
	<b>Jube SP 1P</b> X=160mm (6.3 INCHES)
	<b>Jube SP S</b> X=104mm (4.1 INCHES)

3X 4  
Max 0.2 Nm

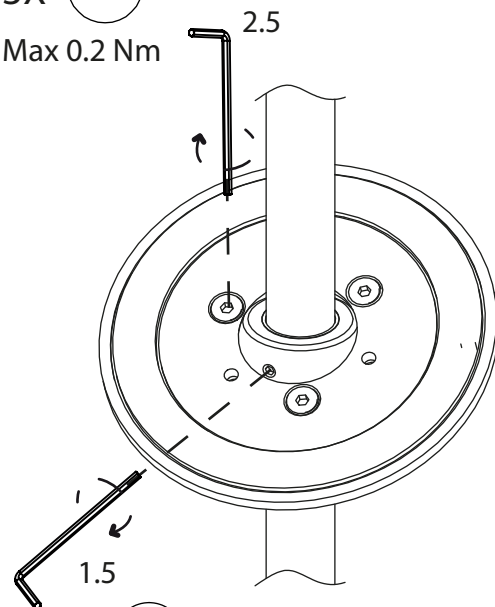

3X 3  
Min 0.3 Nm

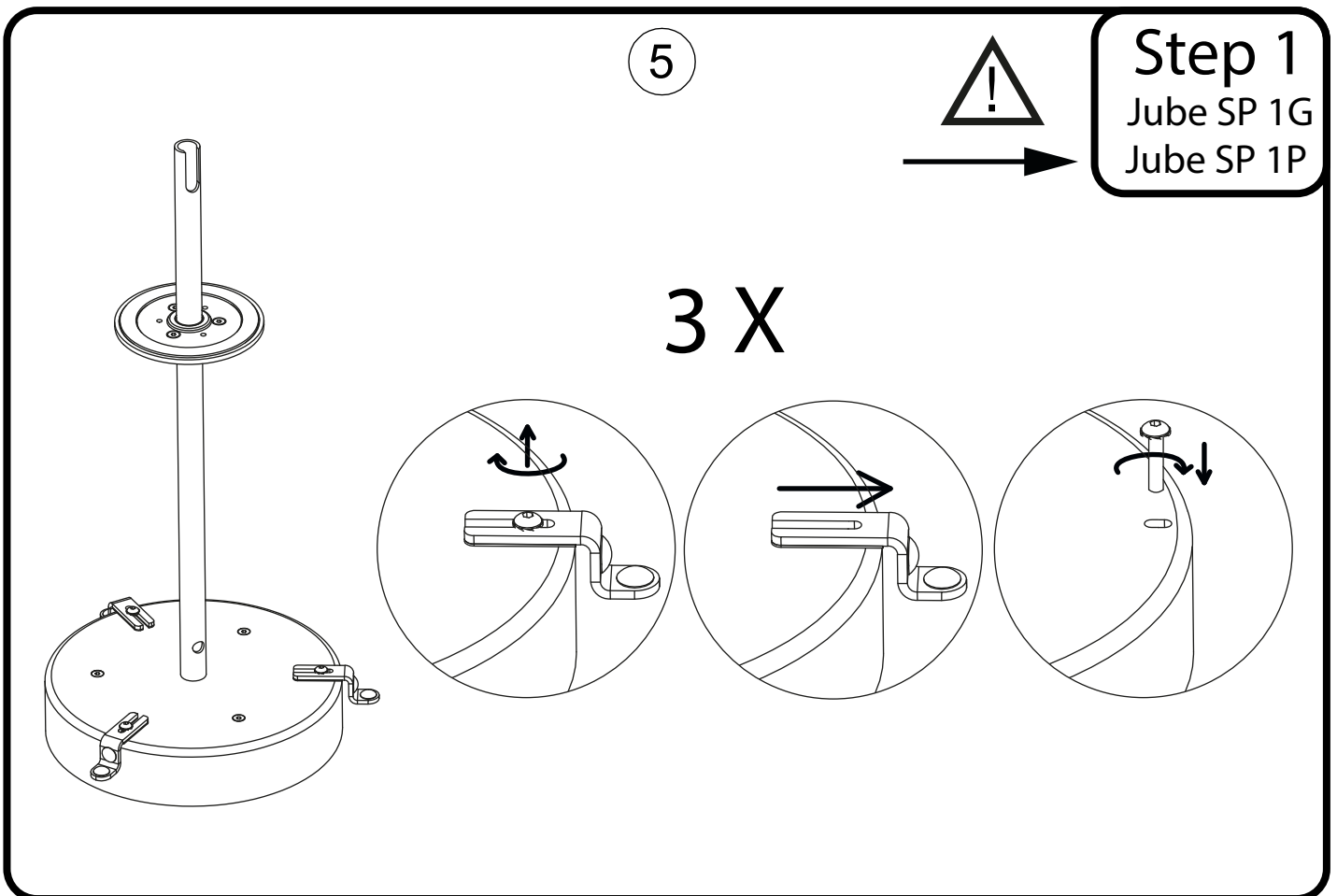
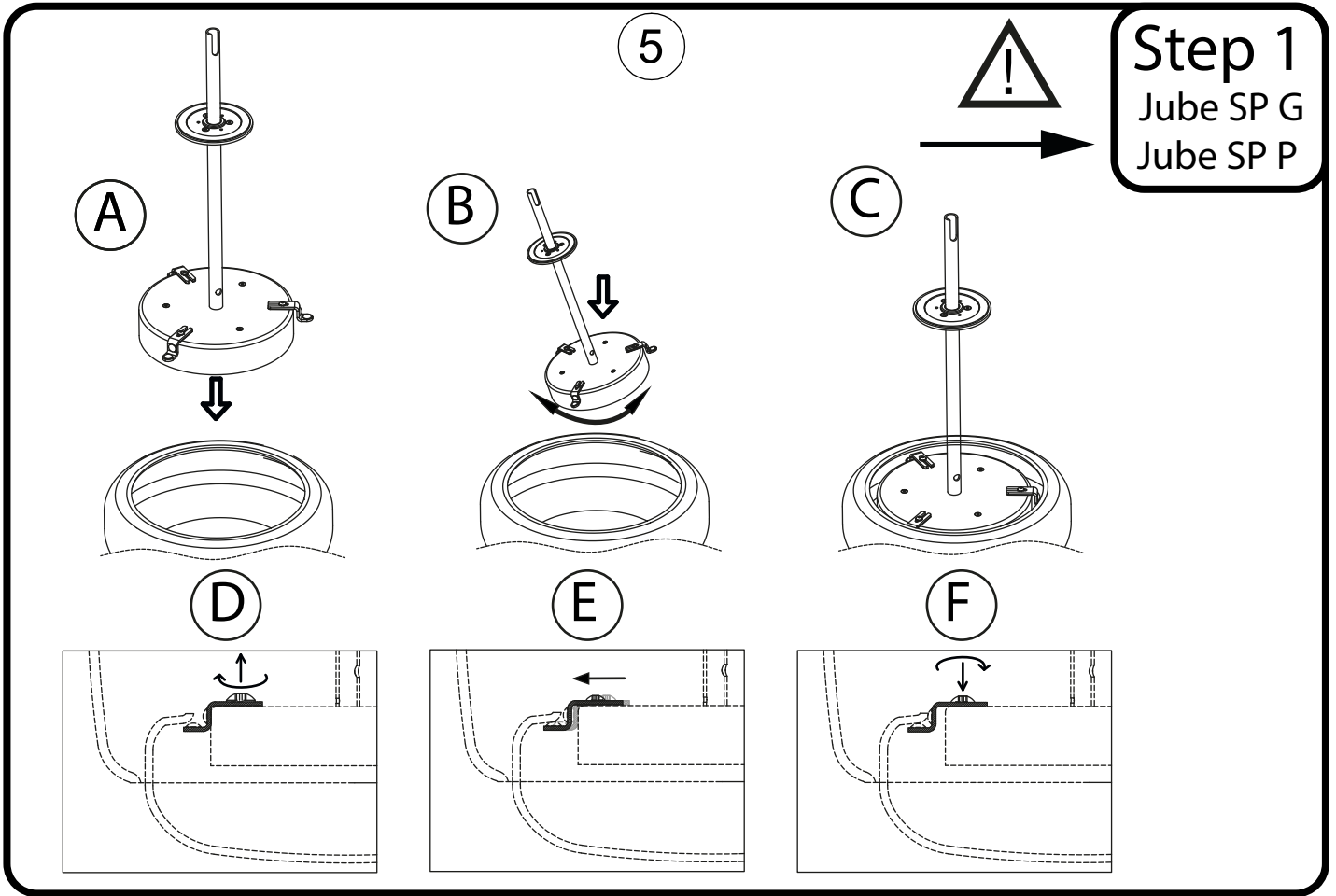

## Step 1

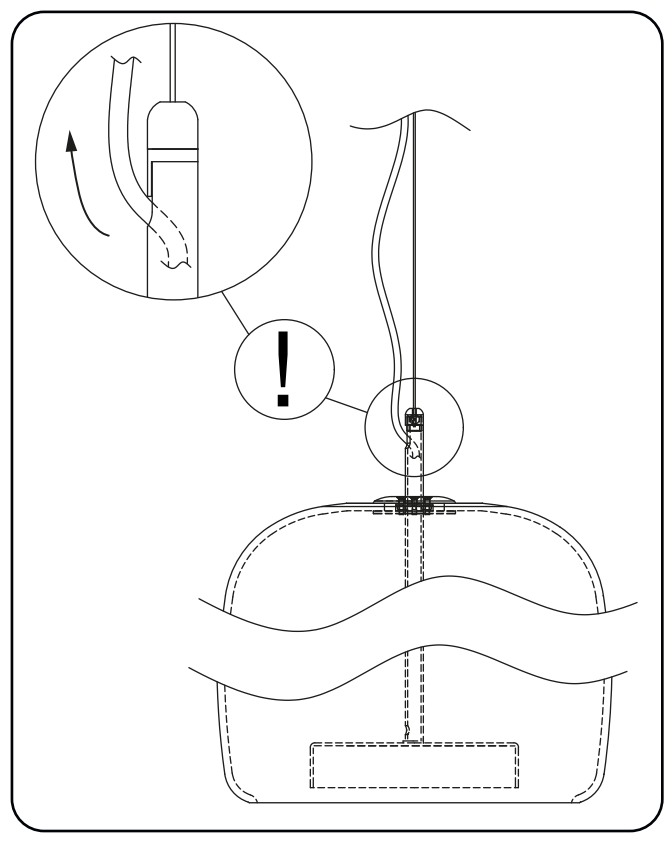
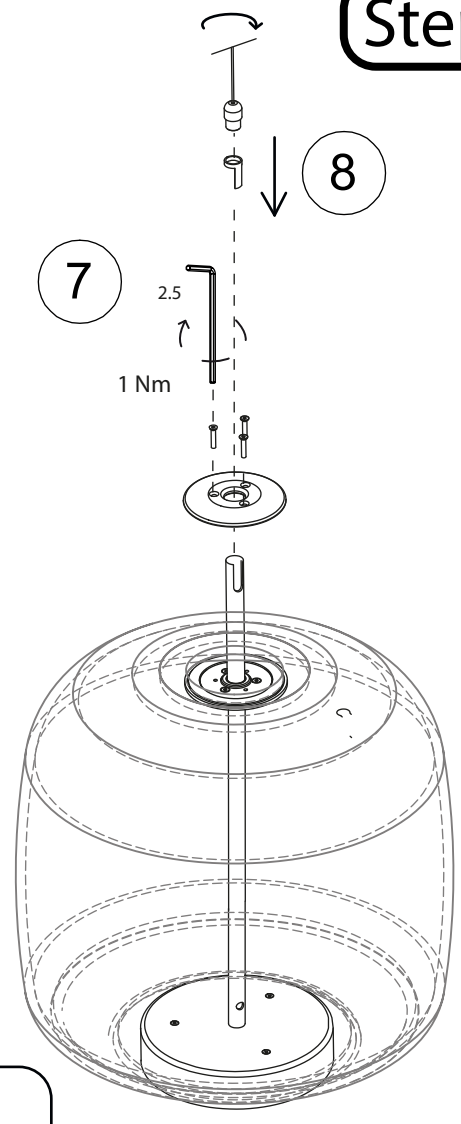
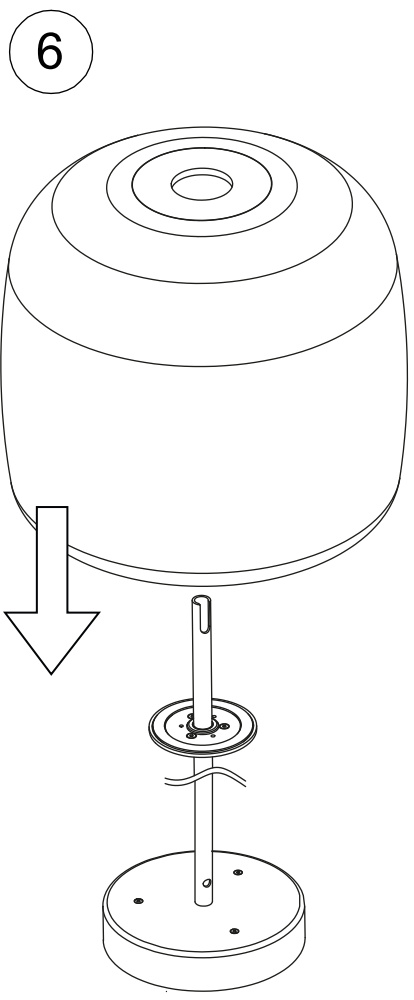

## Step 1

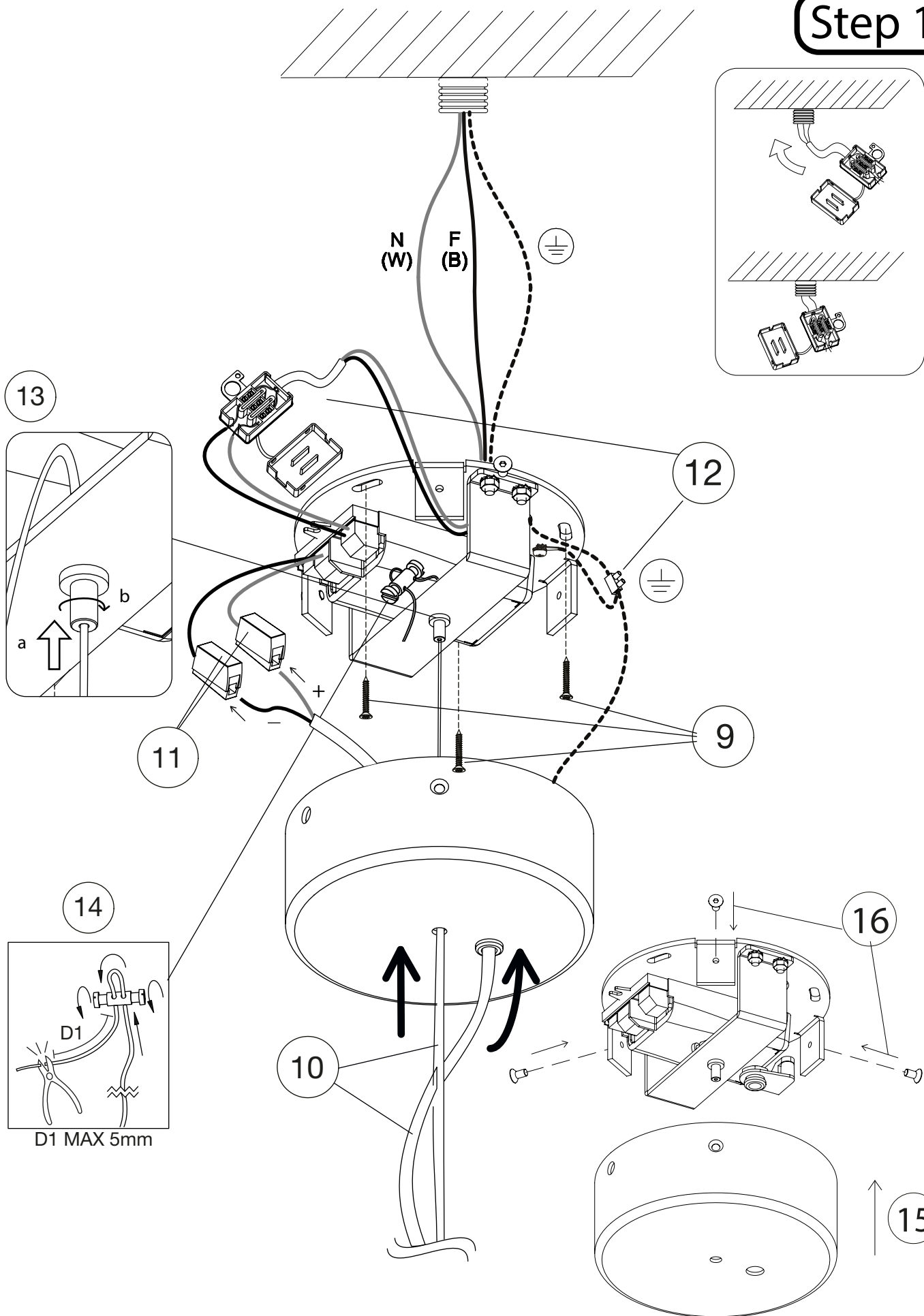

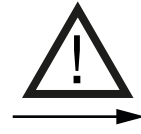
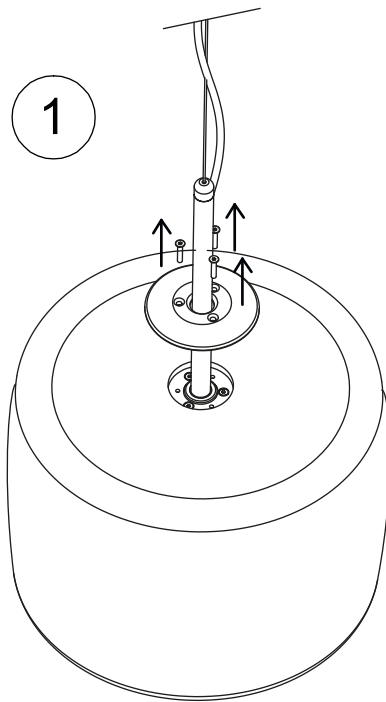

**Step 2**  
Jube SP G  
Jube SP P

2

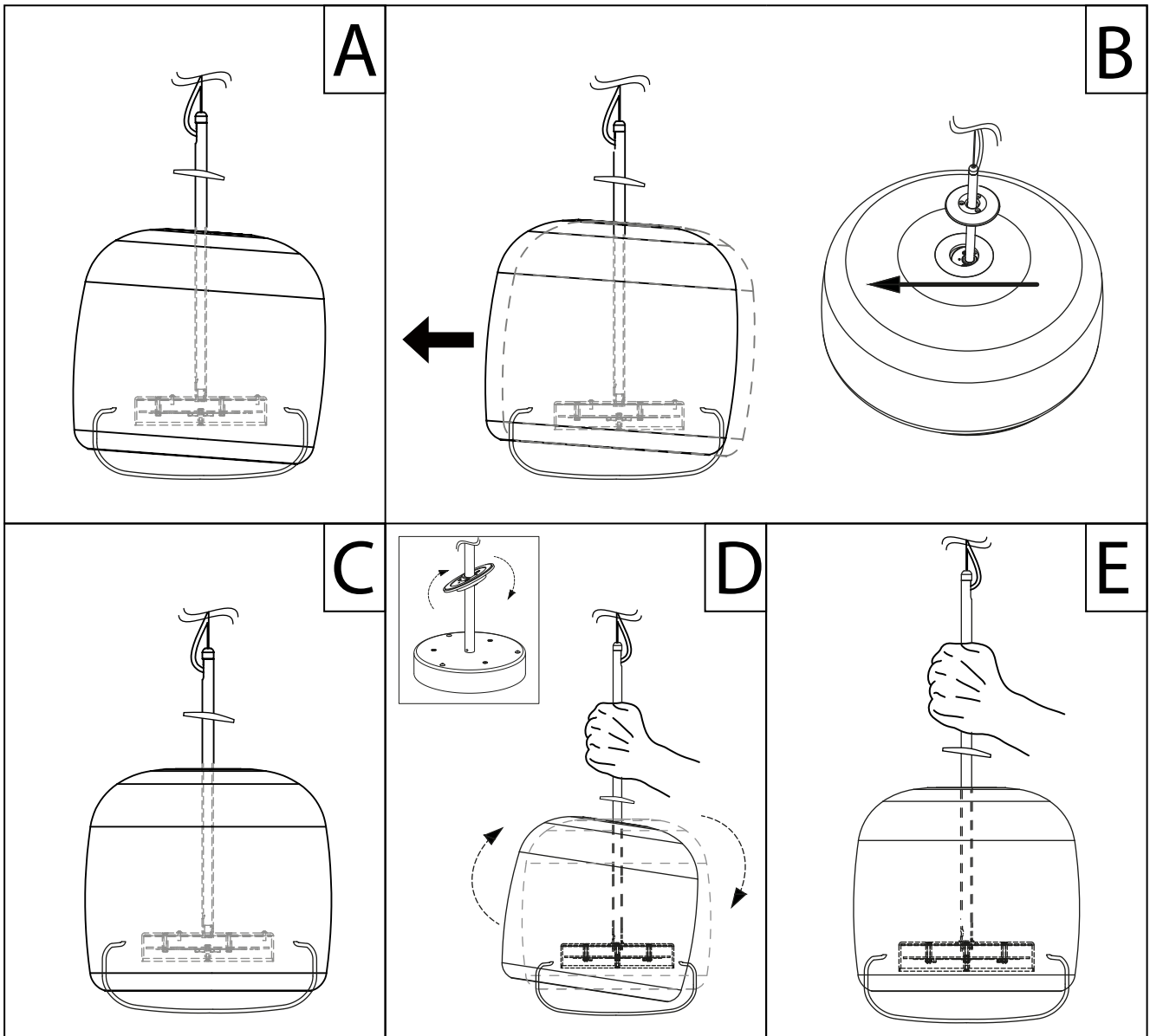

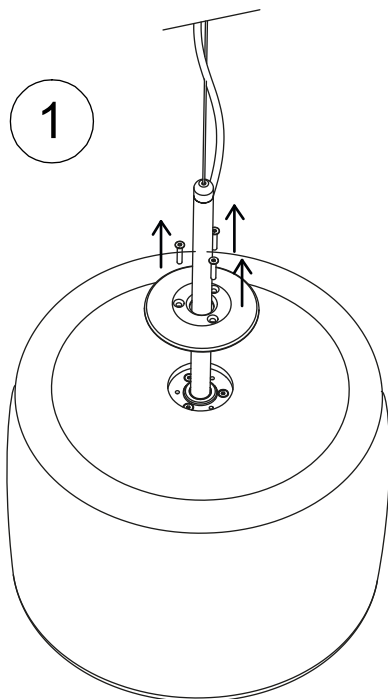

**Step 2**  
 Jube SP G1  
 Jube SP P1

2

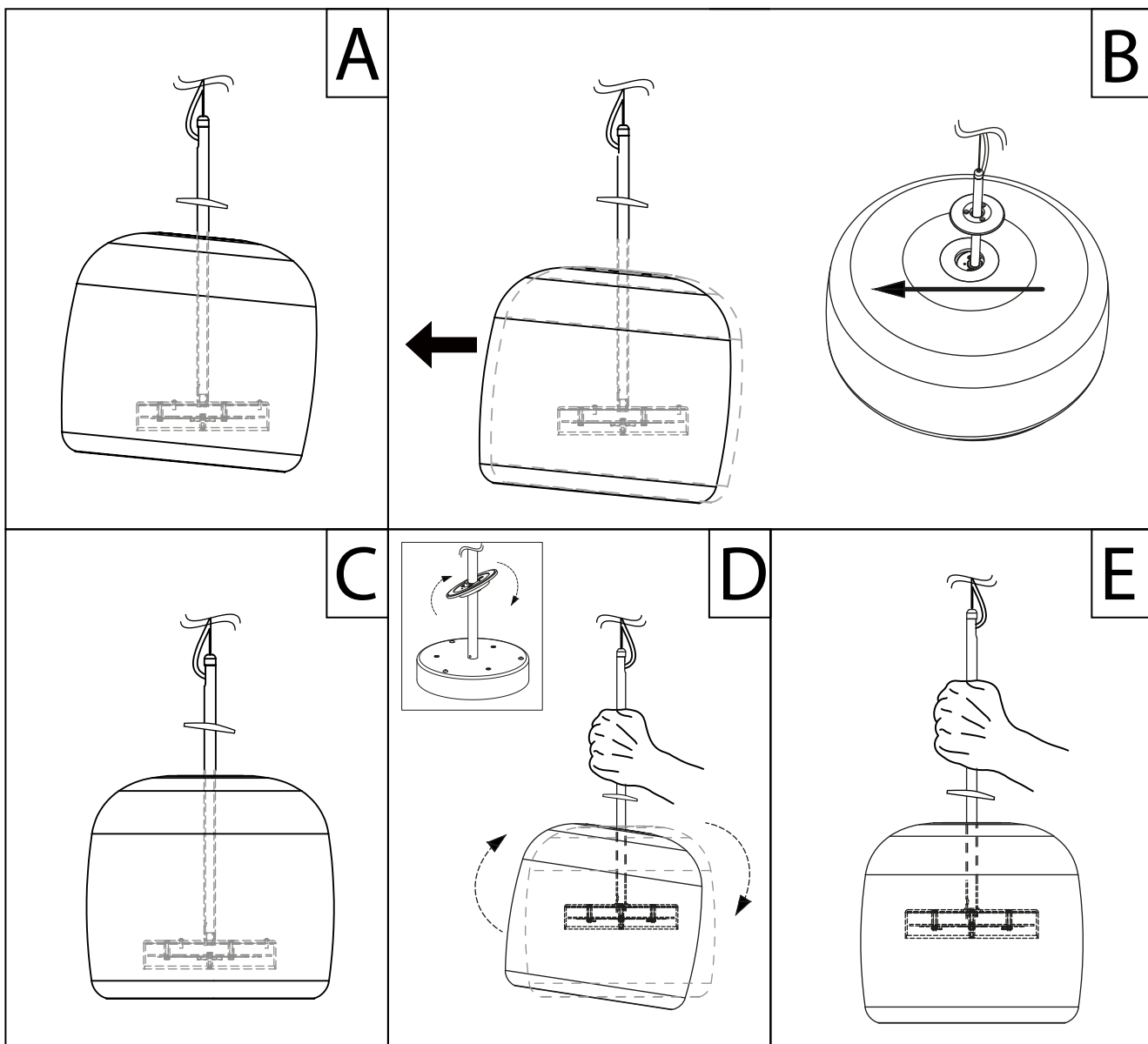

## Step 2

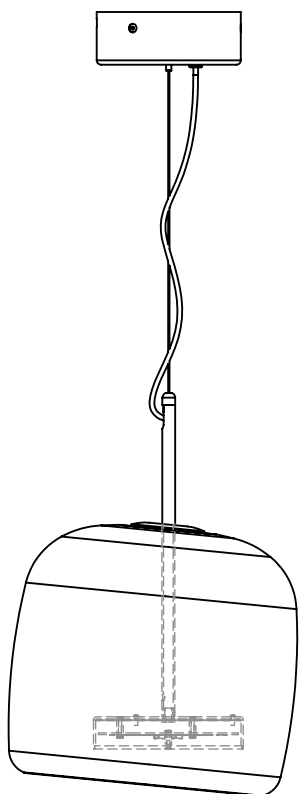
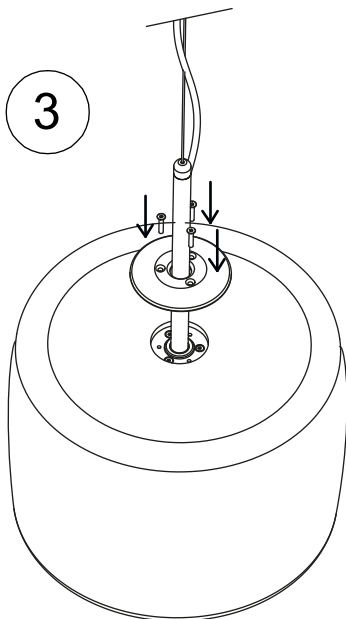

✗ NO

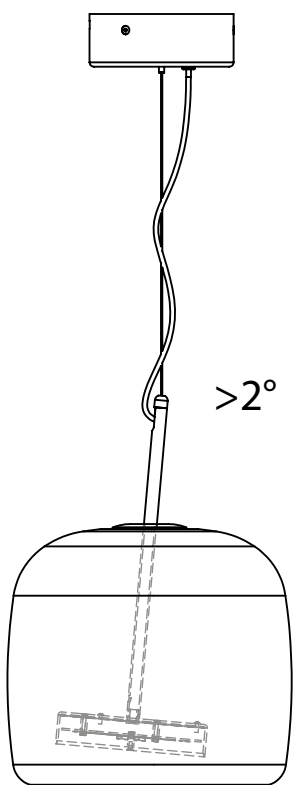

✗ NO

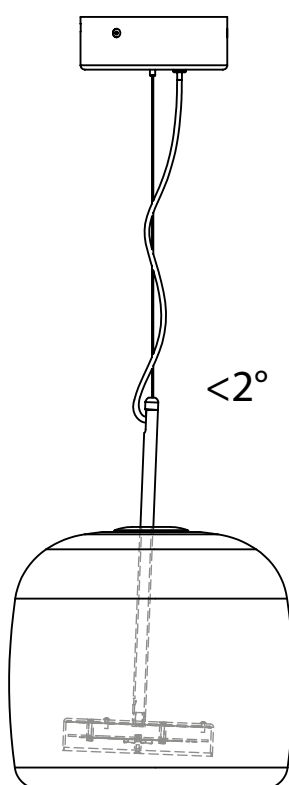

✓ OK

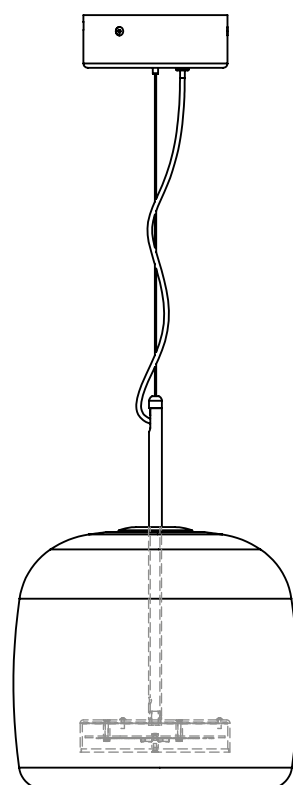

✓ OK

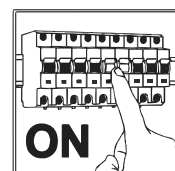



## D1-D2

