

## ECOS

Design RENATO TOSO, NOTI MASSARI e ASSOCIATI

## ECOS PL 90

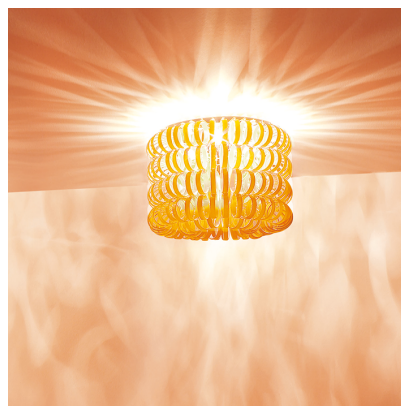

Collezione di lampade componibili con anelli di vetro di diversi colori e textures. È una soluzione d'illuminazione che offre grandissima possibilità di personalizzazione in termini di forme e misure.



## ECOS PL 90

### DATI TECNICI:

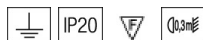

### CERTIFICAZIONI:



### SORGENTI LUMINOSE

E27  5x77W 220-240V 50/60 Hz E27

VOLUME Mc 0,46  
 PESO LORDO Kg 21  
 PESO NETTO Kg 18

download risorse

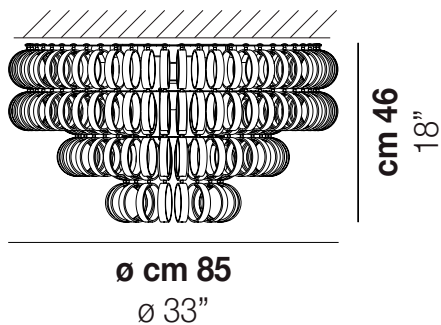

### FINITURA DEL DIFFUSORE



BC/RI

CR/RI

### FINITURA MONTATURA

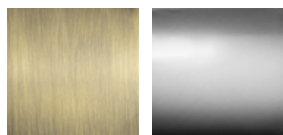

BS

CR

### ALTRE VERSIONI DISPONIBILI

clicca sul disegno per accedere alla pagina web della relativa product sheet

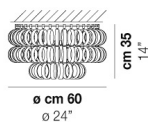

ECOS PL 60A