

**1** Piede anteriore.  
Front leg.  
Vorder Fuß.  
Pied antérieur.

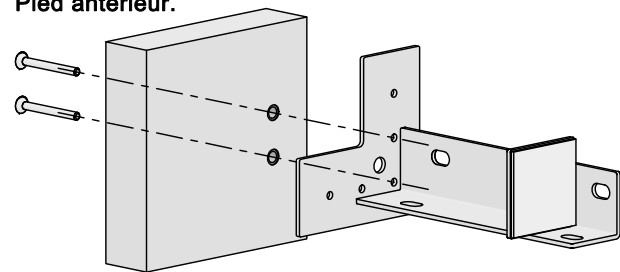

Piede posteriore.  
Back leg.  
Hintere Fuß.  
Pied derrière.

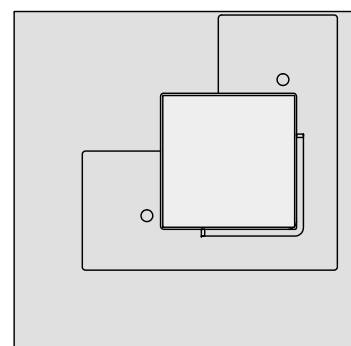
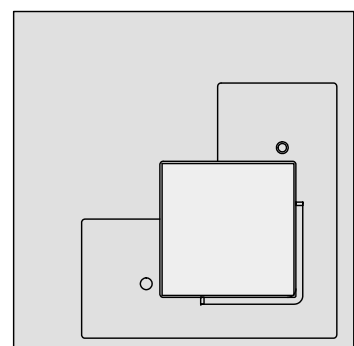
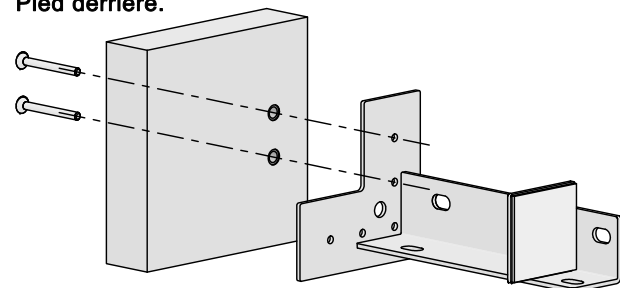

N° 08 TPSCE M8x55 ZB.

N° 01 da 05.

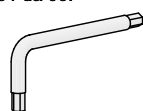

**2**

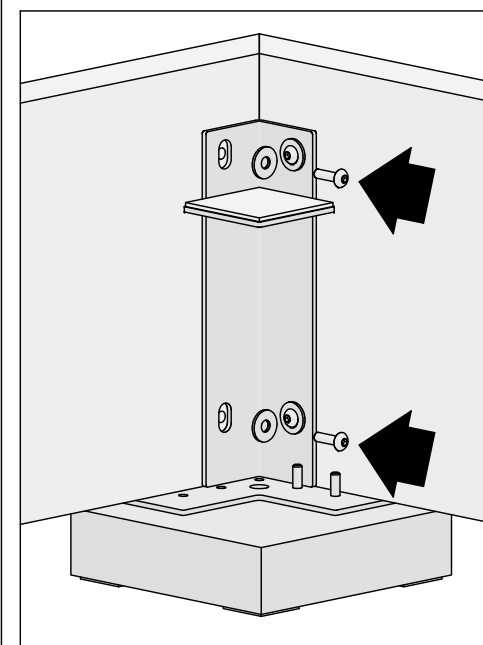

**IMPORTANT!!!!**

Piede anteriore.  
Front leg.  
Vorder Fuß.  
Pied antérieur.

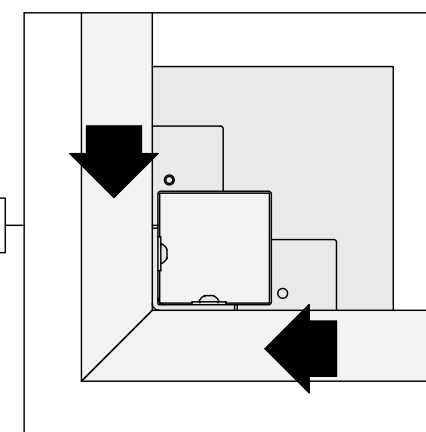

N° 08 TBCE M8x25 ZB.

N° 08 ø 8x24 ZB.

N° 01 da 05.

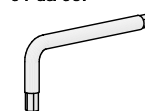
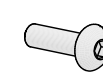

**3**

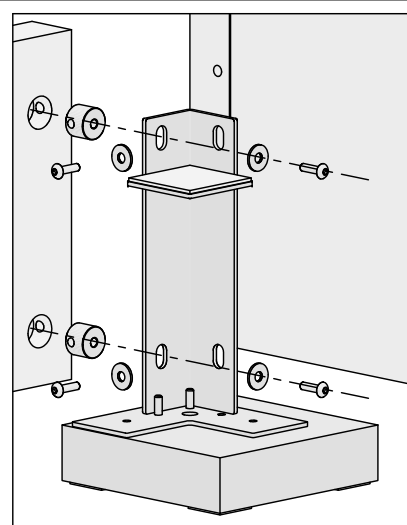

Piede posteriore.  
Back leg.  
Hintere Fuß.  
Pied derrière.

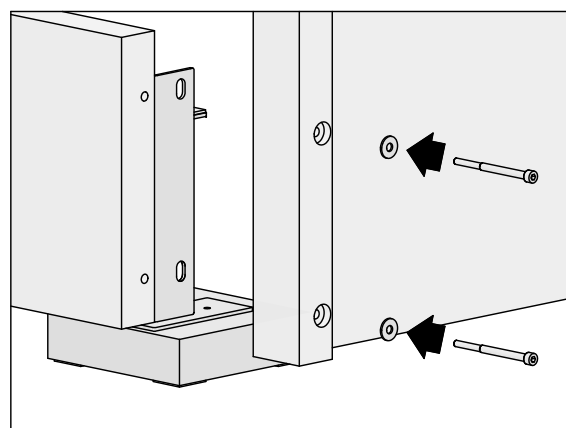
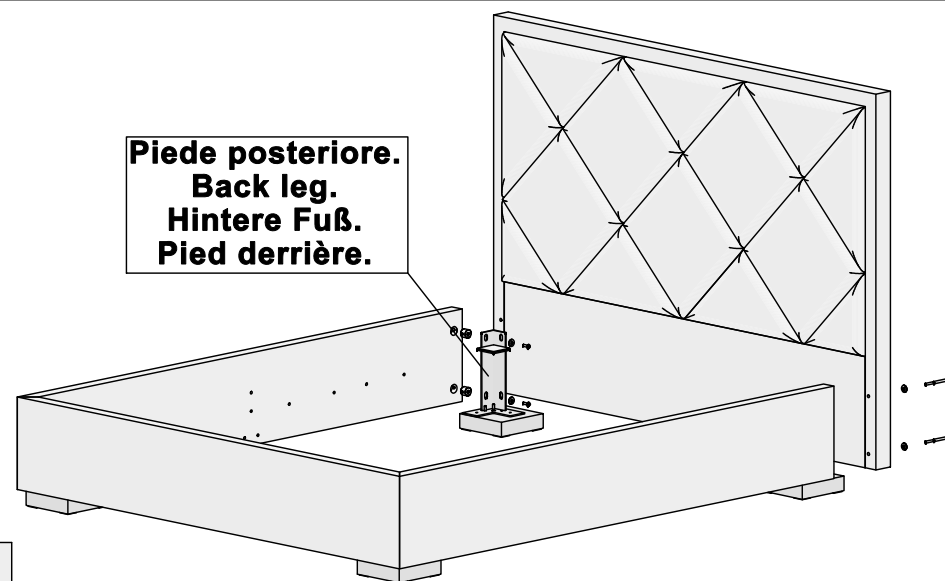

N° 08 TBCE M8x25 ZB.

N° 04 TCCE M8x110 ZB.

N° 12 ø 8x24 ZB.

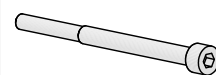
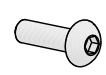

N° 04 cod. 219076000835.

N° 01 da 05.

N° 01 da 06.

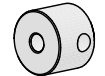

**4**

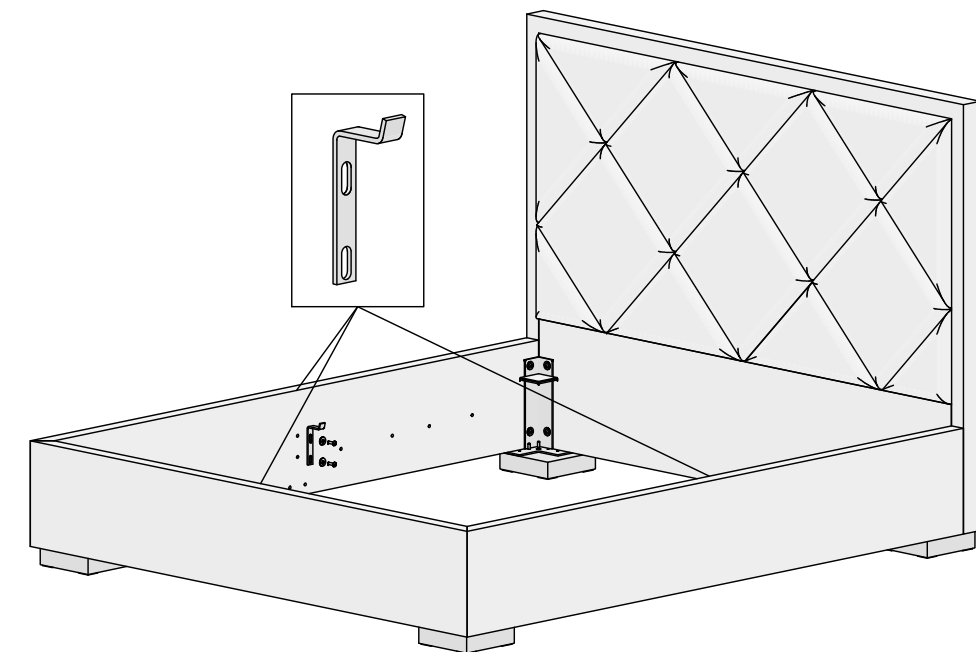
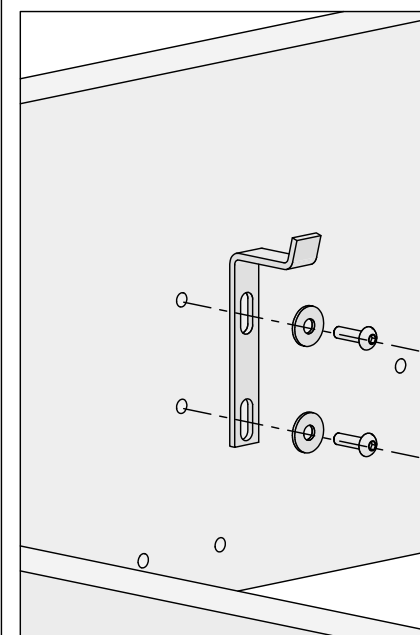

N° 03 cod. 215609500100.

N° 06 TBCE M8x25 ZB.

N° 06 ø 8x24 ZB.

N° 01 da 05.

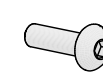
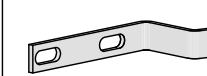

5

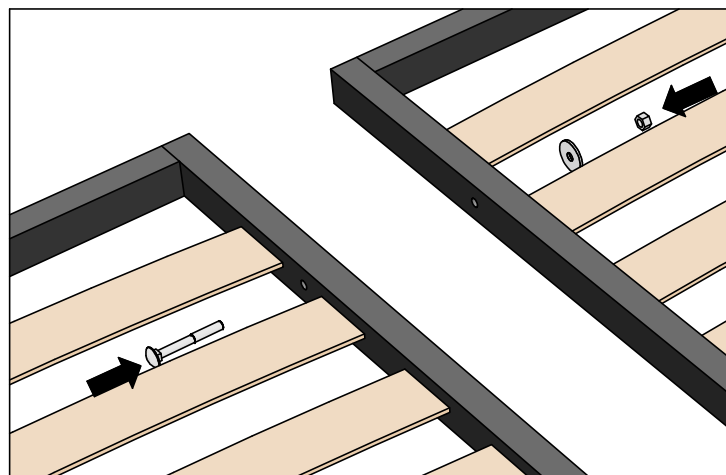
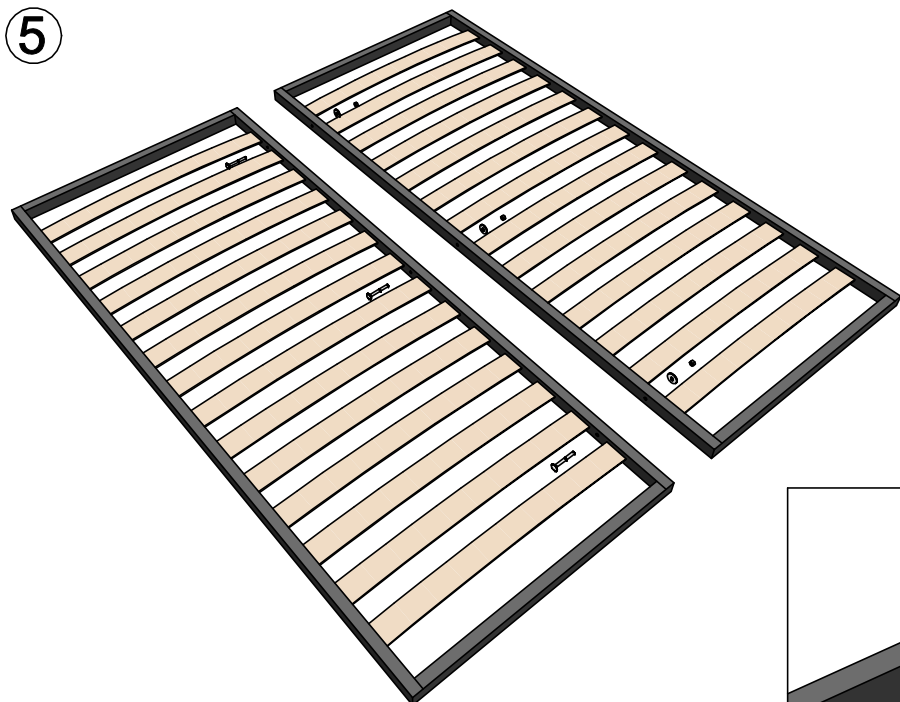

N° 03 TTDE M8x70 ZB.

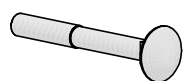

N° 03 ø 8x32 ZB.



N° 03 M8 medio ZB.



6

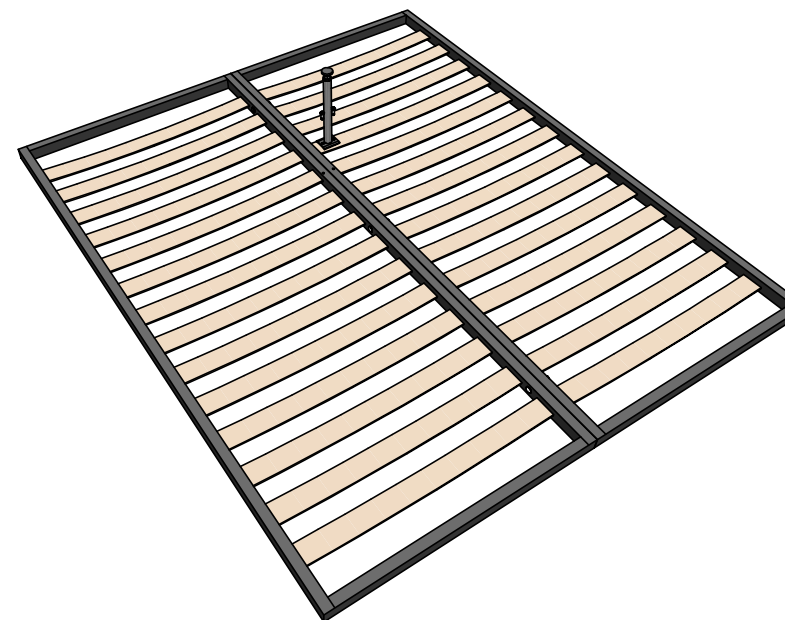

x 2 pz.

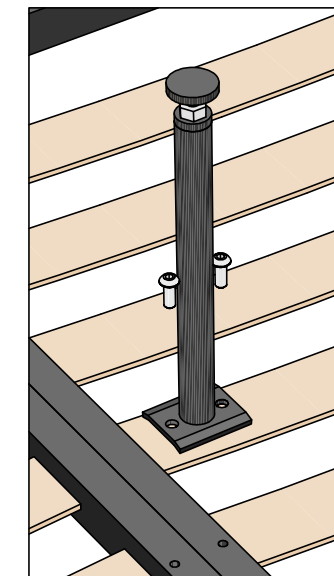

N° 04 TBCE M8x20 N.

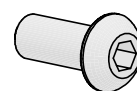

N° 02.

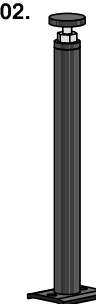

N° 01 da 5.

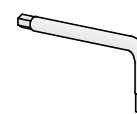

Fissare la gamba centrale regolabile alla rete.

Fix the adjustable central leg to the slats.

Das mittige höhenverstellbare Bein am Lattenrost befestigen.

Fixer la jambe centrale réglable au sommier.

Fijar la pata central regulable al somier.

7

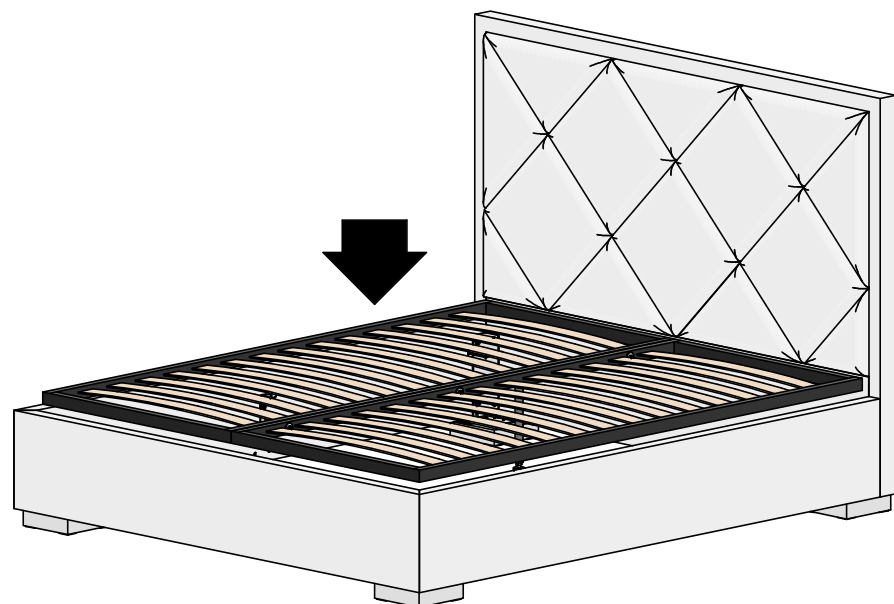

Inserire la rete all'interno del giro letto.  
Put the slats inside the metal frame of the bed.  
Lattenrost auf den Trägern legen.  
Insérer le sommier à l'intérieur du périmètre du lit.  
Introducir el somier en el interior de la estructura.

**IMPORTANTE: NON APPOGGIARSI SULLE DOGHE AL MOMENTO DELLA REGOLAZIONE DELLA GAMBA REGOLABILE.**

**IMPORTANT: DO NOT LEAN ON THE SLATS WHILE YOU SETTLE THE CENTRAL ADJUSTABLE LEG.**

**WICHTIG: BEI WIRKUNG AUF DEM MITTIGEN HÖHVERSTELLBAREN BEIN, NICHT AUF DEM LATTENROST LEHNEN.**

**IMPORTANT: NE PAS S'APPUYER AUX LATTES AU MOMENT DU REGLAGE DE LA JAMBE CENTRALE REGLABLE.**

**IMPORTANTE: NO APOYARSE SOBRE LAS CAMAS EN AL MOMENTO DE LA REGULACION DE LA PATA CENTRAL.**

8

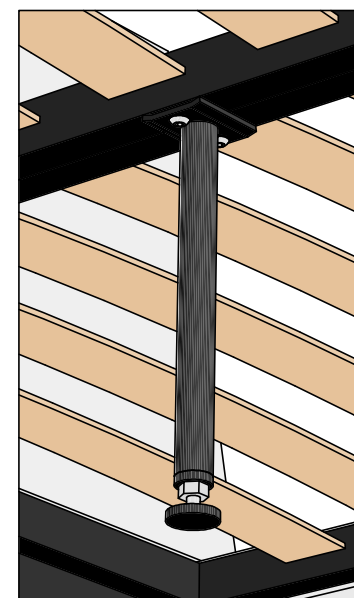

Agire sulla gamba centrale regolabile fissata in precedenza sulla rete portandola in appoggio a pavimento.

Act on the central adjustable leg fixed before on the slats, make it lay on the floor.

Auf dem mittigen höhenverstellbaren Bein wirken, bis zum dies am Boden liegt.

Agir sur la jambe centrale réglable (précédemment fixée au sommier), de façon à ce qu'elle se pose au sol.

Regular la pata central fijada anteriormente al somier hasta su apoyo al suelo.

**IMPORTANTE: NON APPOGGIARSI SULLE DOGHE AL MOMENTO DELLA REGOLAZIONE DELLA GAMBA REGOLABILE.**

**IMPORTANT: DO NOT LEAN ON THE SLATS WHILE YOU SETTLE THE CENTRAL ADJUSTABLE LEG.**

**WICHTIG: BEI WIRKUNG AUF DEM MITTIGEN HÖHVERSTELLBAREN BEIN, NICHT AUF DEM LATTENROST LEHNEN.**

**IMPORTANT: NE PAS S'APPUYER AUX LATTES AU MOMENT DU REGLAGE DE LA JAMBE CENTRALE REGLABLE.**

**IMPORTANTE: NO APOYARSE SOBRE LAS CAMAS EN AL MOMENTO DE LA REGULACION DE LA PATA CENTRAL.**