

ESTILUZ NOVELTIES / Metal is the principle element, malleable and durable, capable of rendering pure forms as the central thesis of design. Quality, sensitivity to detail and timelessness are the values we add.



**estiluz**<sup>®</sup>

# NOVELTIES

<sup>(ENG)</sup> Since 1969, we have honored our heritage and family traditions, our passion for lighting, and our expertise in shaping metal, all while continuing to expand our horizons through creativity, research, and innovation. Commitment to human values and experience drives our design and production to the highest quality. We constantly seek a balance between function, aesthetics, and sustainability with lamps that offer rational design and adaptability to user needs.

<sup>(ESP)</sup> Desde 1969, conservamos nuestra herencia y tradición familiar, preservando la pasión por la luz y la habilidad de dar forma al metal a la vez que ampliamos nuestros horizontes a través de la innovación, la creatividad y la emoción. El valor humano, el compromiso y la experiencia son el motor que impulsa nuestro diseño y producción de lámparas metálicas de alta calidad. Buscamos constantemente el equilibrio entre funcionalidad, estética y sostenibilidad, para ofrecer lámparas decorativas de diseño racionalista, adaptables a las necesidades del proyecto.

# TIK

*Boti de Dominicis Studio*



<sup>(ENG)</sup> TIK presents a unique simplicity of profile with quality details and intersecting volumes that gives it a distinctive yet subtle presence.

<sup>(ESP)</sup> Su simplicidad contrasta con la calidad de los detalles, una delicada intersección de los distintos volúmenes aporta a TIK un interesante rasgo diferencial en el escenario de la iluminación para exterior.







(ENG) TIK transforms an element as primary and accessible as a tube to create a captivating collection of luminaires designed to enhance outdoor spaces and with an earthy palette to complement its surroundings.

(ESP) TIK transforma un elemento tan simple y accesible como un tubo, en una cautivadora colección de luminarias diseñadas para realzar espacios exteriores.





TIK 4096X

LED 6,2W  
(2700K / Ang. 80°  
>90 CRI / 350mA) / 230V  
Typ\* 725 lumens

Non dimmable  
Hard wired (no plug)  
Non-ajustable tube  
enclosing light source

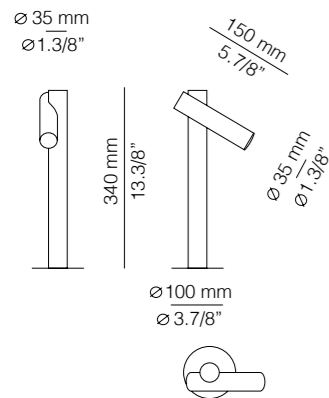

TIK 4097X

LED 6,2W  
(2700K / Ang. 80°  
>90 CRI / 350mA) / 230V  
Typ\* 725 lumens

Non dimmable  
Hard wired (no plug)  
Non-ajustable tube  
enclosing light source

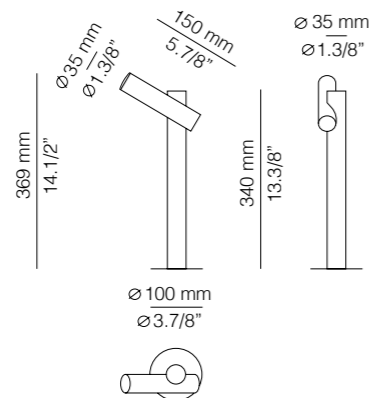

TIK 4098X

LED 6,2W  
(2700K / Ang. 80°  
>90 CRI / 350mA) / 230V  
Typ\* 725 lumens

Non dimmable  
Hard wired (no plug)  
Non-ajustable tube  
enclosing light source

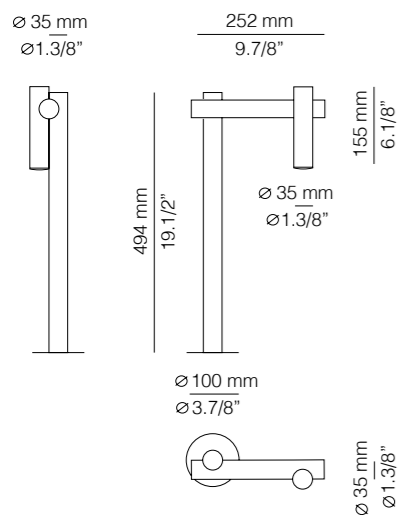

TIK 4099X

LED 6,2W  
(2700K / Ang. 80°  
>90 CRI / 350mA) / 230V  
Typ\* 725 lumens

Non dimmable  
Hard wired (no plug)  
Non-ajustable tube  
enclosing light source

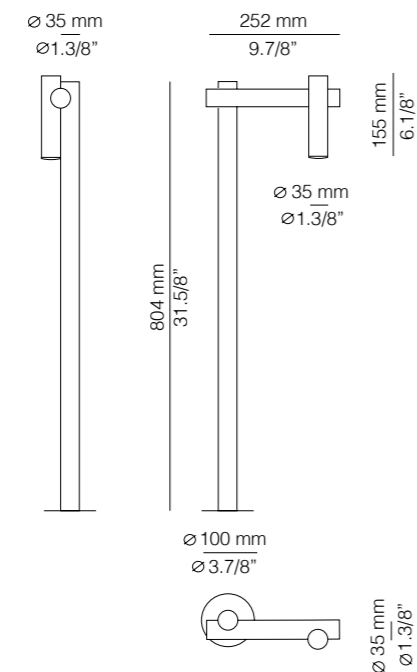

Finishes

- 88 GREY STONE
- 89 PALE GREEN
- 96 BLACK ANTHRACITE

Additional

We offer custom finishes, sizes, and alternate lamping for projects.

*Photographs may show non-standard products.*





<sup>(ENG)</sup> TIK's minimalism is characterized by a geometric purity while adding visual richness to its environment. <sup>(ESP)</sup> Un producto minimalista caracterizado por una extrema pureza geométrica, pero a la vez capaz de transmitir y aportar una importante riqueza visual en el entorno en el que va a convivir.





## TIK 4090X

LED 3W  
(2700K / Ang.80° / >90CRI  
24V) / 100V-240V  
Typ\* 300 lumens

Remote driver  
Non Dimmable  
Non-ajustable tube  
enclosing light source

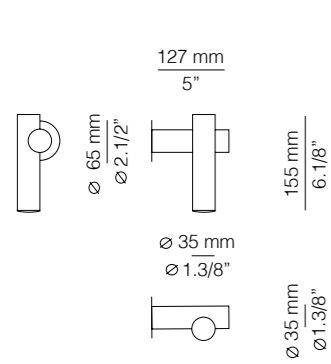

## TIK 4091X

LED 2x3W  
(2700K / Ang.80° / >90CRI  
24V) / 230V  
Typ\* 2x300 lumens

Remote driver  
Non Dimmable  
Non-ajustable tube  
enclosing light source

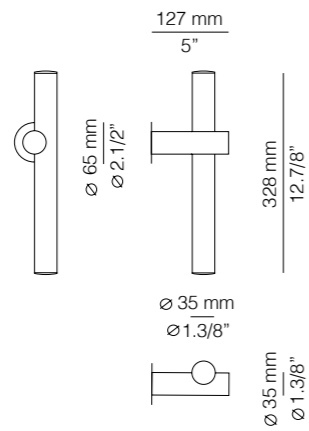

### Finishes

- 88 GREY STONE
- 89 PALE GREEN
- 96 BLACK ANTHRACITE

### Additional

We offer custom finishes, sizes, and alternate lamping for projects.

*Photographs may show non-standard products.*



Private residence by @joanpuigcorbepaas



TIK 4090

LED 6,2W  
(2700K / Ang.30° / >90CRI  
300mA) / 230V  
Typ\* 652 lumens

Dimmable triac  
Non-ajustable tube  
enclosing light source

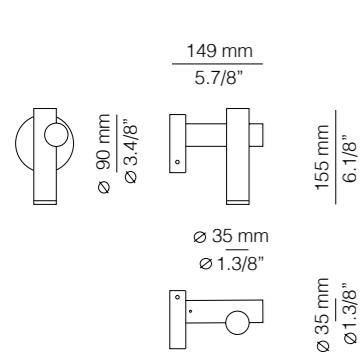

TIK 4091

LED 2x3W  
(2700K / Ang.30° / >90CRI  
300mA) / 230V  
Typ\* 2x350 lumens

Dimmable triac  
Non-ajustable tube  
enclosing light source

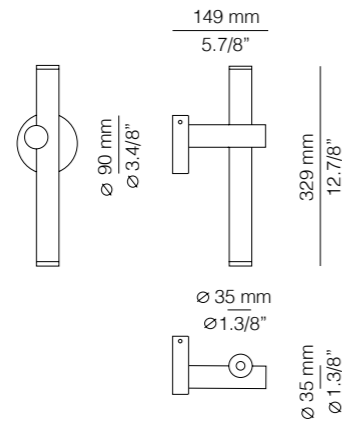

Finishes

- 61 SATIN GOLD
- 88 GREY STONE
- 96 BLACK ANTHRACITE

Additional

We offer custom finishes, sizes, and alternate lamping for projects.

*Photographs may show non-standard products.*

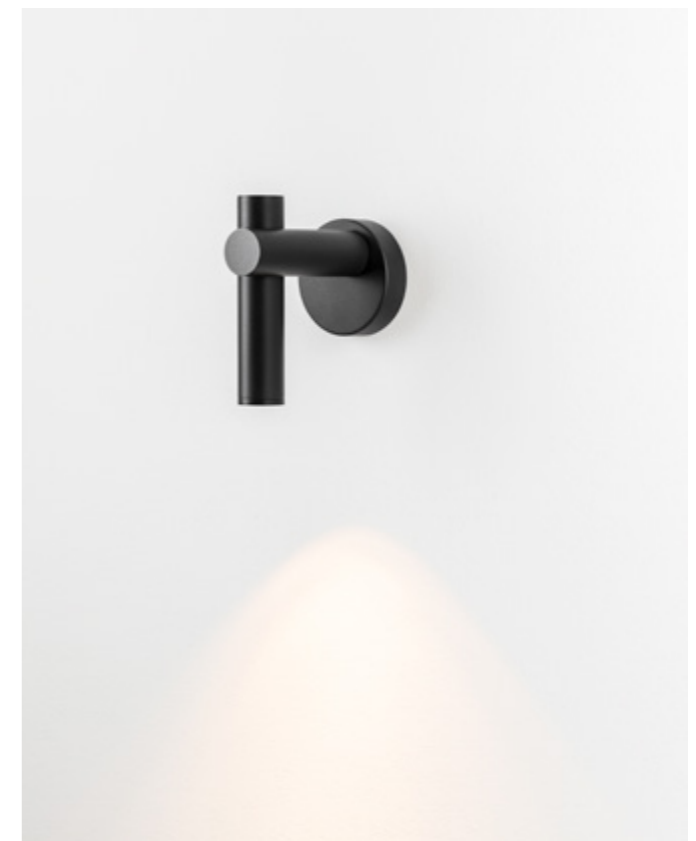
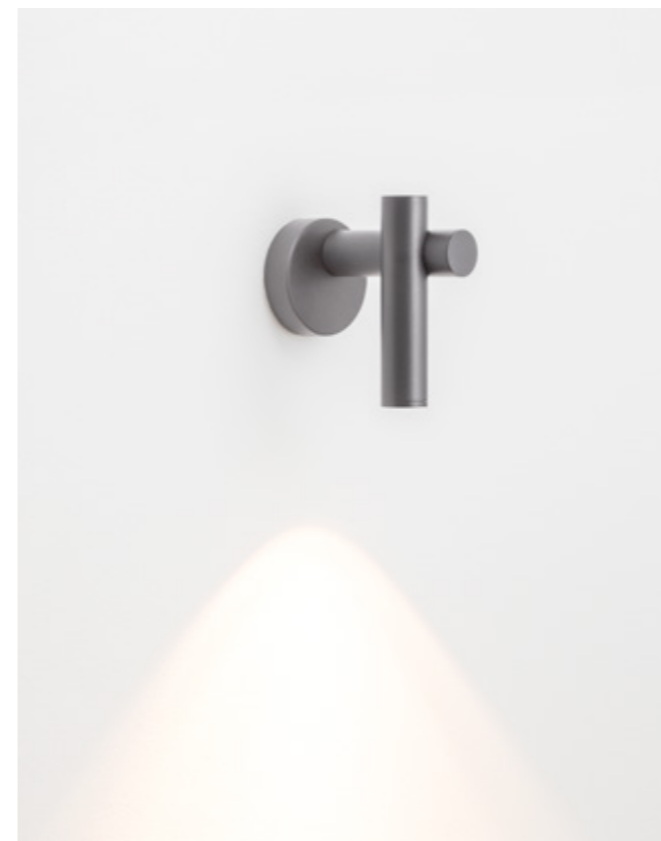
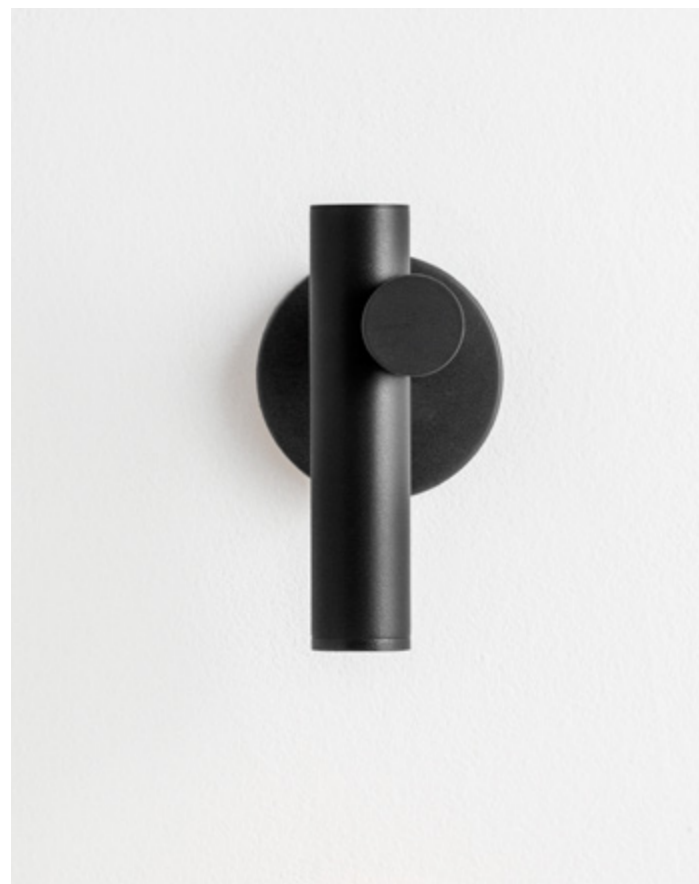
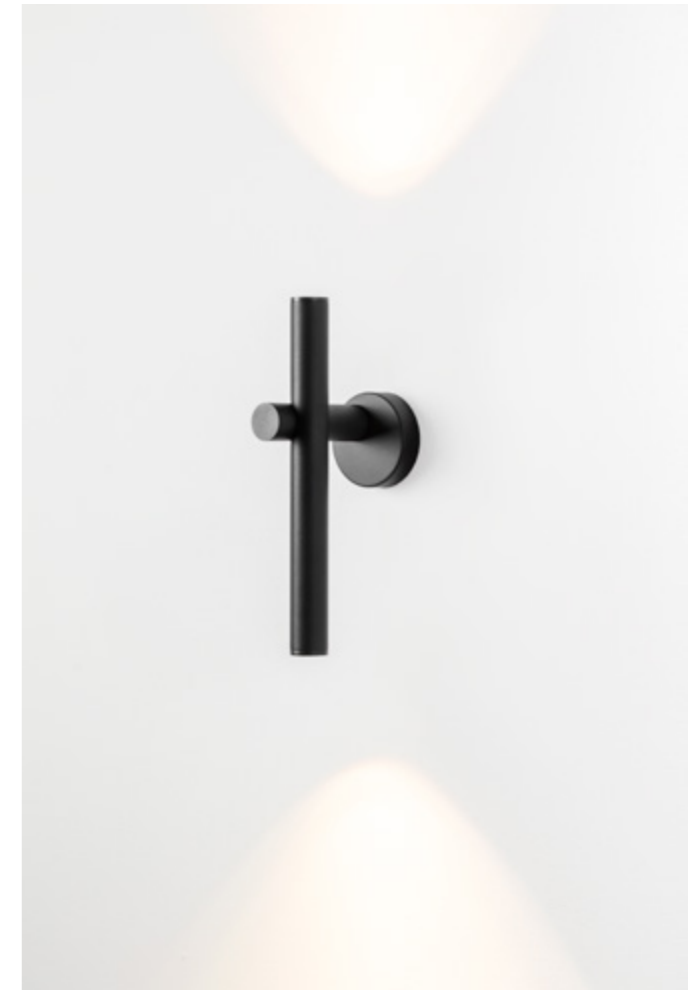

# MOOD

*Nahtrang Studio*



<sup>(ENG)</sup> Mood redefines lighting with its exceptional combination of flexibility, portability, and versatility. Its different possibilities arise from a rounded shade that hides an LED strip and turns the lamp into a unique and hypnotic piece. <sup>(ESP)</sup> Mood redefine la iluminación con su excepcional combinación de flexibilidad, transportabilidad y versatilidad. Sus diferentes posibilidades surgen a partir de una pantalla redondeada que esconde una tira LED y convierte a la lámpara en una pieza única e hipnótica.





(ENG) A single shade can be attached to different supports and in different positions, easily transforming into four different types of lamps.  
(ESP) Un solo cabezal puede ser acoplado a distintos soportes y en distintas posiciones, para convertirse fácilmente en diferentes tipos de lámparas.







<sup>(ENG)</sup> Mood's innovative design dissuades its users from placing it in a fixed location and facilitates that it can be moved from one place to another without complications or installations. <sup>(ESP)</sup> El diseño innovador de Mood evita que la lámpara tenga un emplazamiento fijo y facilita que pueda ser trasladada de un lugar a otro sin complicaciones ni instalaciones.

### MOOD 4066

LED 19W  
 (2700K / Ang.120° / >80 CRI / 24V)  
 100V - 240V / Typ\* 1800 lumens  
 Push button dimmer on the cord  
 Universal plug

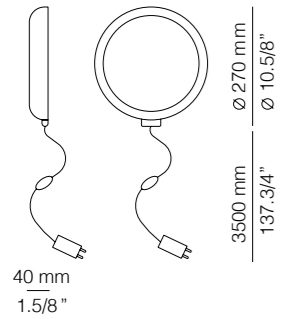

### MOOD 4060

LED 19W  
 (2700K / Ang.120° / >80 CRI / 24V)  
 100V - 240V / Typ\* 1800 lumens  
 Push button dimmer on the cord  
 Universal plug

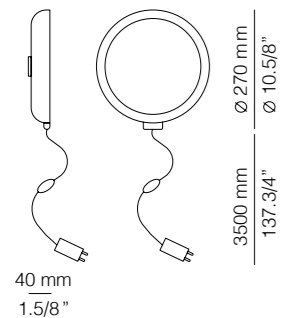

### MOOD 4067

LED 19W  
 (2700K / Ang.120° / >80 CRI / 24V)  
 100V - 240V / Typ\* 1800 lumens  
 Push button dimmer on the cord  
 Universal plug

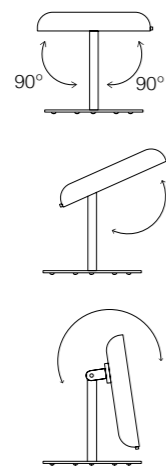
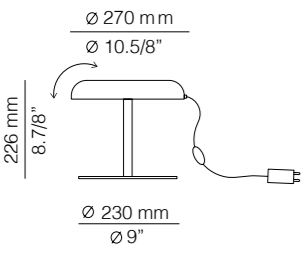

### MOOD 4061

LED 19W  
 (2700K / Ang. 120° / >80 CRI / 24V)  
 100V - 240V / Typ\* 1800 lumens  
 Push button dimmer on the cord  
 Universal plug

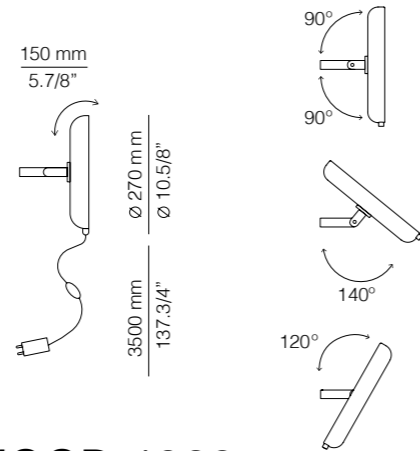

### MOOD 4068

LED 19W  
 (2700K / Ang. 120° / >80 CRI / 24V)  
 100V - 240V / Typ\* 1800 lumens  
 Push button dimmer on the cord  
 Universal plug

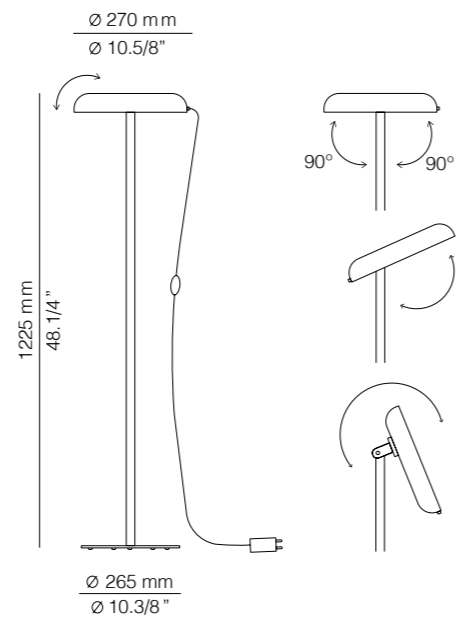

#### Finishes

- 91 NUDE
- 74 WHITE

#### Additional

We offer custom finishes, sizes, and alternate lamping for projects.

*Photographs may show non-standard products.*





## MOOD 4065

LED 19W  
 (2700K / Ang.120° / >80 CRI / 24V)  
 100V - 240V / Typ\* 1800 lumens  
 Push button dimmer on the cord  
 Universal plug

### Finishes Additional

- 91 NUDE
- 74 WHITE

We offer custom finishes, sizes, and alternate lamping for projects.

*Photographs may show non-standard products.*

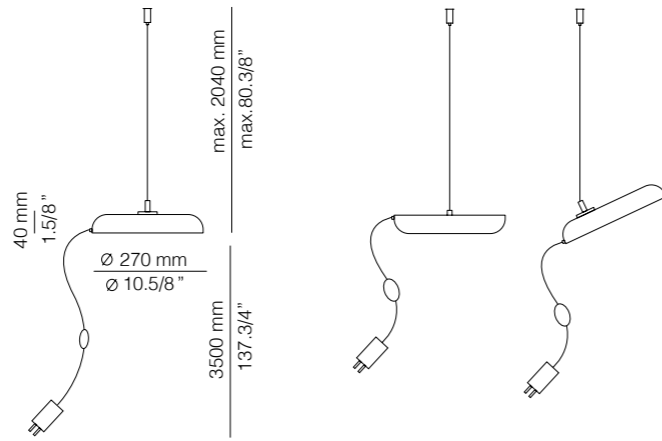
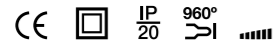

## MOOD 4064S

With surface canopy

LED 19W  
 (2700K / Ang.120° / >80 CRI / 24V)  
 230V / Typ\* 1800 lumens  
 Dimmable triac

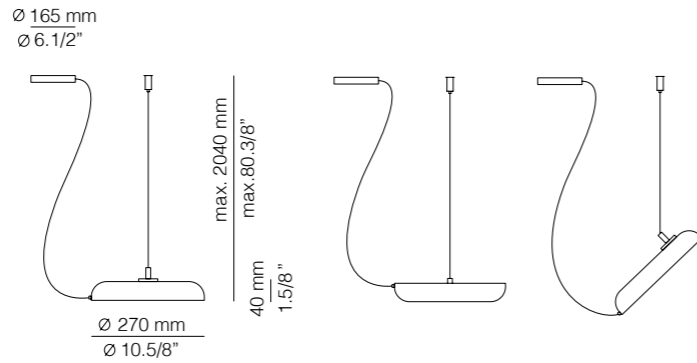

## MOOD 4064R

With recessed canopy

LED 19W  
 (2700K / Ang.120° / >80 CRI / 24V)  
 230V / Typ\* 1800 lumens  
 Dimmable triac

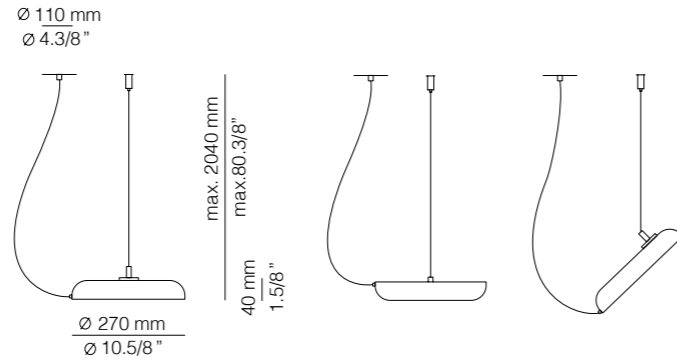

### Finishes Additional

- 91 NUDE
- 74 WHITE

We offer custom finishes, sizes, and alternate lamping for projects.

*Photographs may show non-standard products.*





<sup>(ENG)</sup> The innovative use of magnets on the shade allows Mood to be a direct or indirect light source, easily modified after installation. <sup>(ESP)</sup> El sistema de imanes que sujeta las pantallas, permite su instalación como lámpara de luz directa o indirecta, e incluso su modificación una vez instalada.

Private residence by @joanpuigcorbebaas





**MOOD 4062S**  
With surface canopy

LED 2x19W  
(2700K / Ang.120° / >80 CRI / 24V)  
230V / Typ\* 2x1800 lumens  
Dimmable triac

**Finishes**

- 91 NUDE
- 74 WHITE

**Additional**

We offer custom finishes, sizes, and alternate lamping for projects.

*Photographs may show non-standard products.*

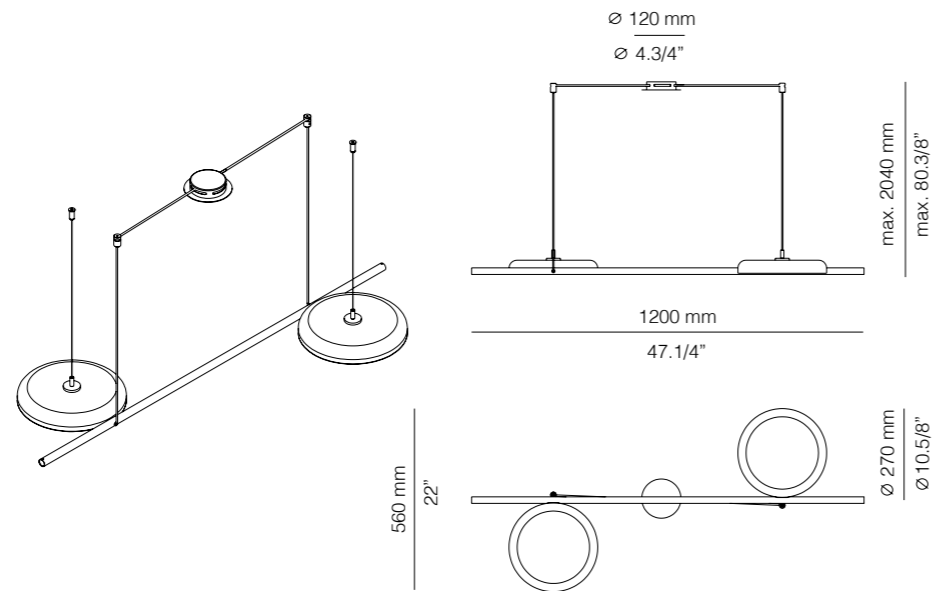
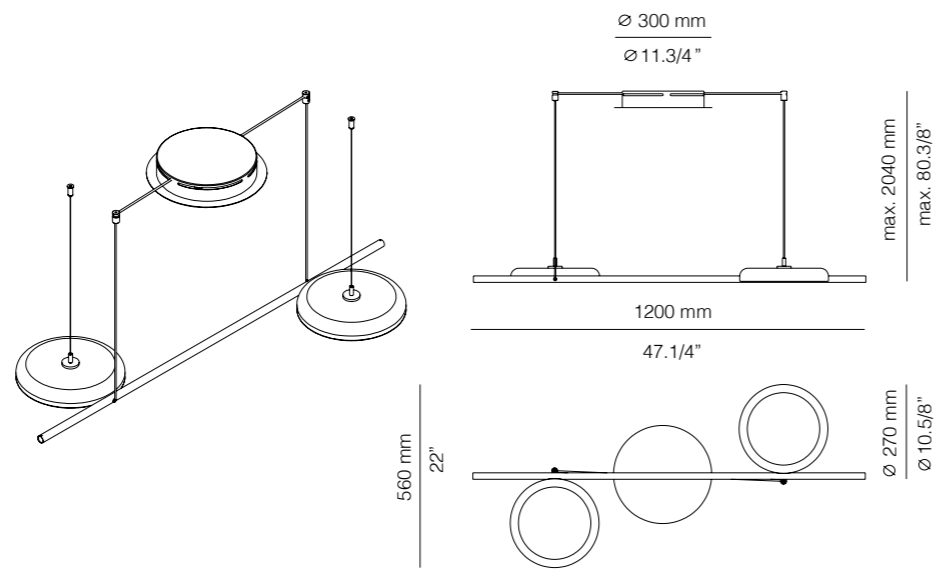

**MOOD 4062R**  
With recessed canopy

LED 2x19W  
(2700K / Ang.120° / >80 CRI / 24V)  
230V / Typ\* 2x1800 lumens  
Dimmable triac

**Finishes**

- 91 NUDE
- 74 WHITE

**Additional**

We offer custom finishes, sizes, and alternate lamping for projects.

*Photographs may show non-standard products.*

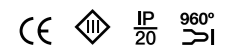



**MOOD 4063S**  
With surface canopy

LED 3x19W  
(2700K / Ang.120° / >80 CRI / 24V)  
100V - 277V / Typ\* 3x1800 lumens  
Dimmable 1-10V

**Finishes**

- 91 NUDE
- 74 WHITE

**Additional**

We offer custom finishes, sizes, and alternate lamping for projects.

*Photographs may show non-standard products.*

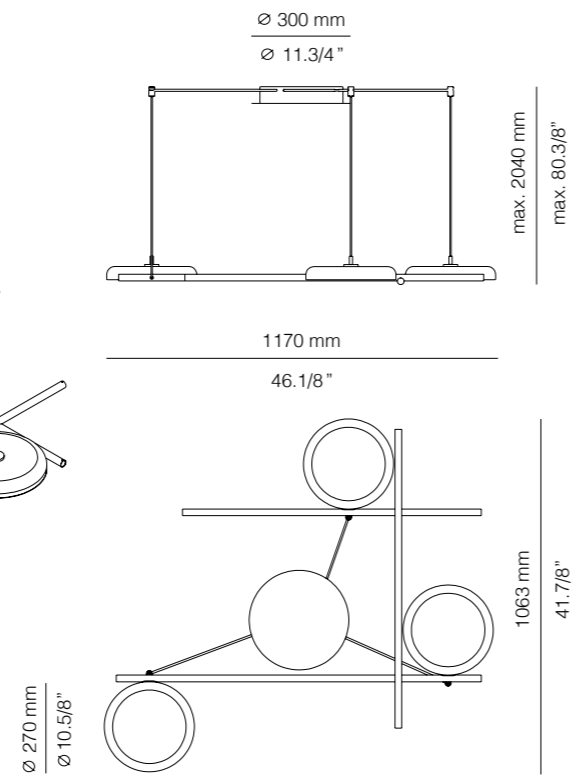
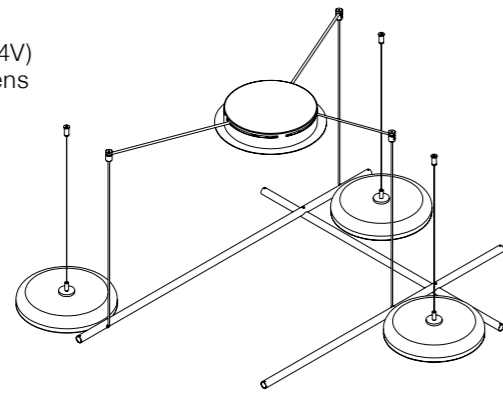

**MOOD 4063R**  
With recessed canopy

LED 3x19W  
(2700K / Ang.120° / >80 CRI / 24V)  
100V - 277V / Typ\* 3x1800 lumens  
Dimmable 1-10V

**Finishes**

- 91 NUDE
- 74 WHITE

**Additional**

We offer custom finishes, sizes, and alternate lamping for projects.

*Photographs may show non-standard products.*

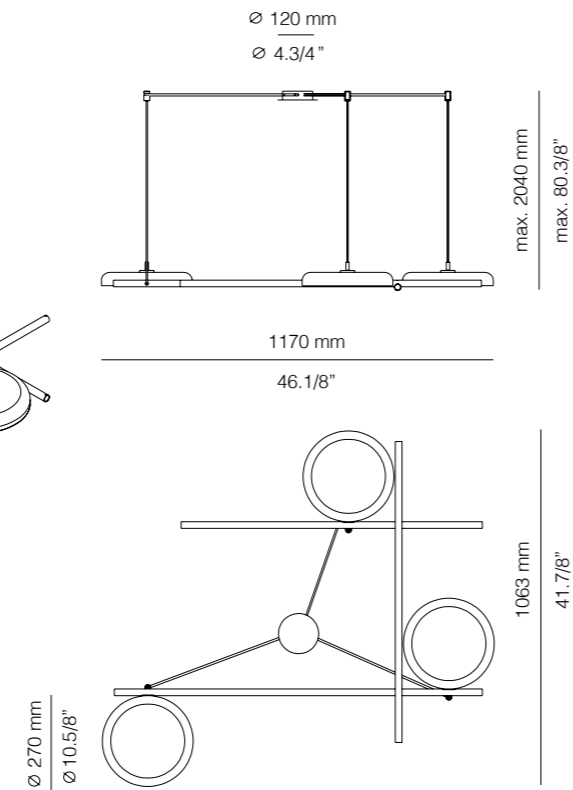
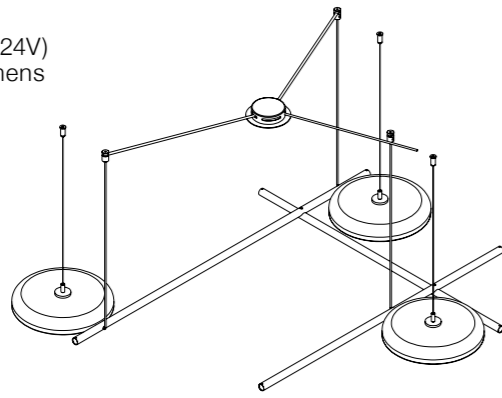
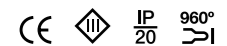

Many possible compositions  
with 4062 and 4063

MOOD L92S2D

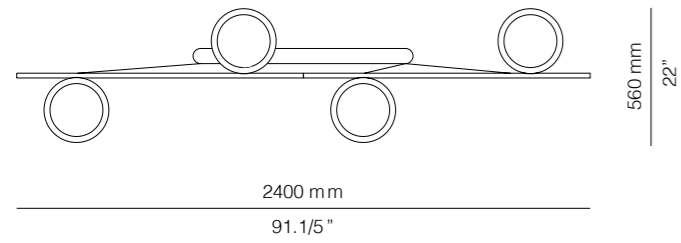

MOOD L92S1D1T

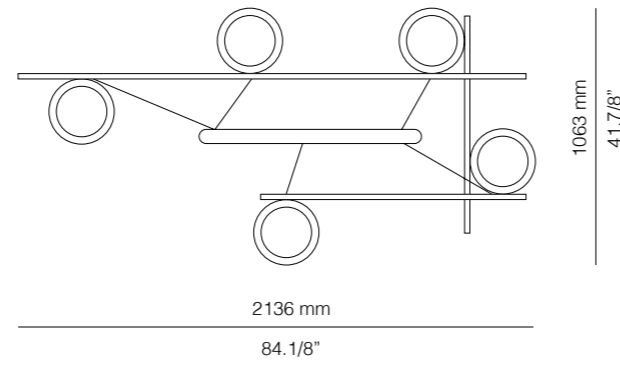

MOOD L92S2TV1

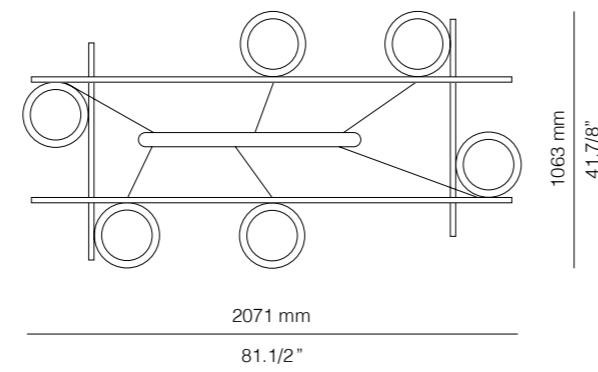

MOOD L92S2TV2

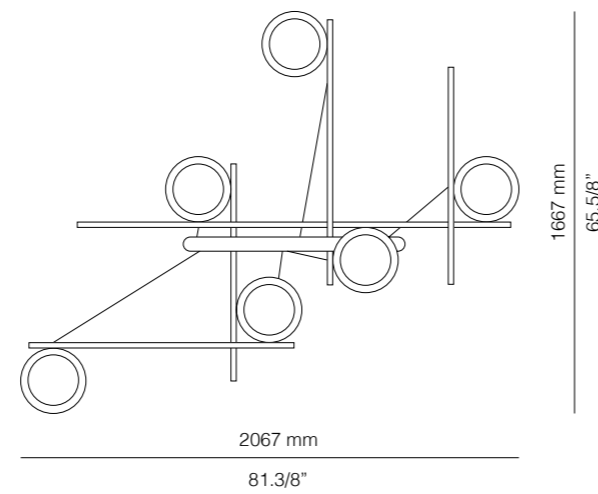

# COMPASS

*Nahtrang Studio*



<sup>(ENG)</sup> Compass is a simple sphere on a wire and attached to an aircraft cable: not only a delicate and timeless reference but a means to transform spaces with its form and structure, either singly or in multiples. <sup>(ESP)</sup> Compass destila sensibilidad en sus líneas puras y sencillas, a partir de delicadas referencias del arte y la vida cotidiana. El conjunto de luminarias transforma una gran diversidad de espacios con una narrativa atemporal de forma y estructura.







(ENG) A subtle counterweight slides vertically to allow the repositioning and functionality of Compass to be quickly changed at any time.

(ESP) La suspensión se caracteriza por un sutil contrapeso que se desliza verticalmente y que permite cambiar la geometría y funcionalidad de la lámpara en cualquier momento.

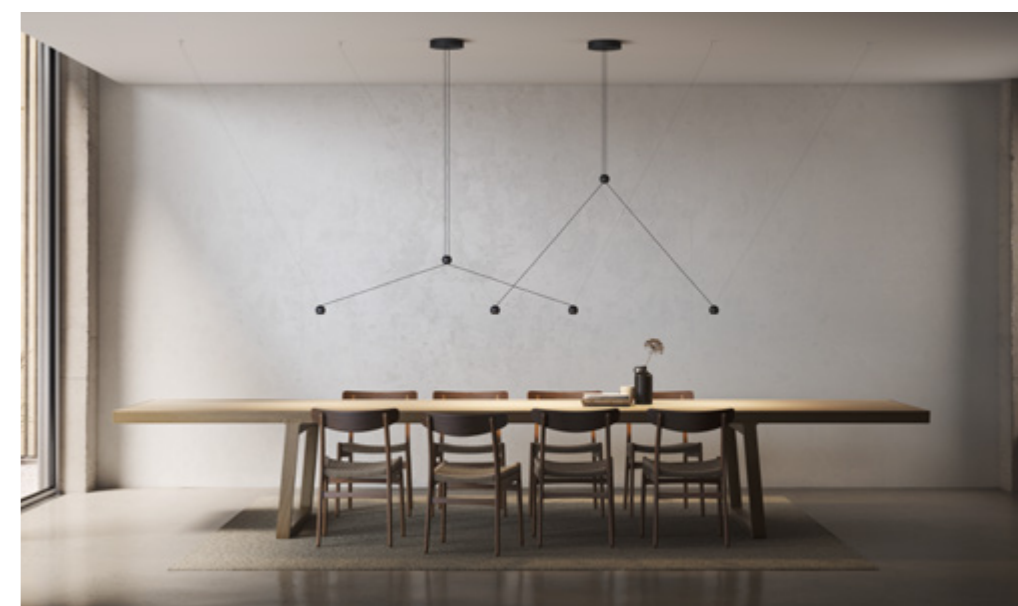



(ENG) Compass is conceived as a luminaire that can be configured with two, four, or six heads. (ESP) Compass se concibe como una luminaria compuesta que permite dos, cuatro y seis pantallas.





(ENG) The flexibility and versatility of individual suspension open up a world of surprising and playful compositional possibilities, either through repetition or by transforming it into a wall light. (ESP) La flexibilidad y versatilidad de la suspensión individual abre un mundo de sorprendentes y lúdicas posibilidades compositivas, ya sea a través de la repetición o al convertirla en un aplique.

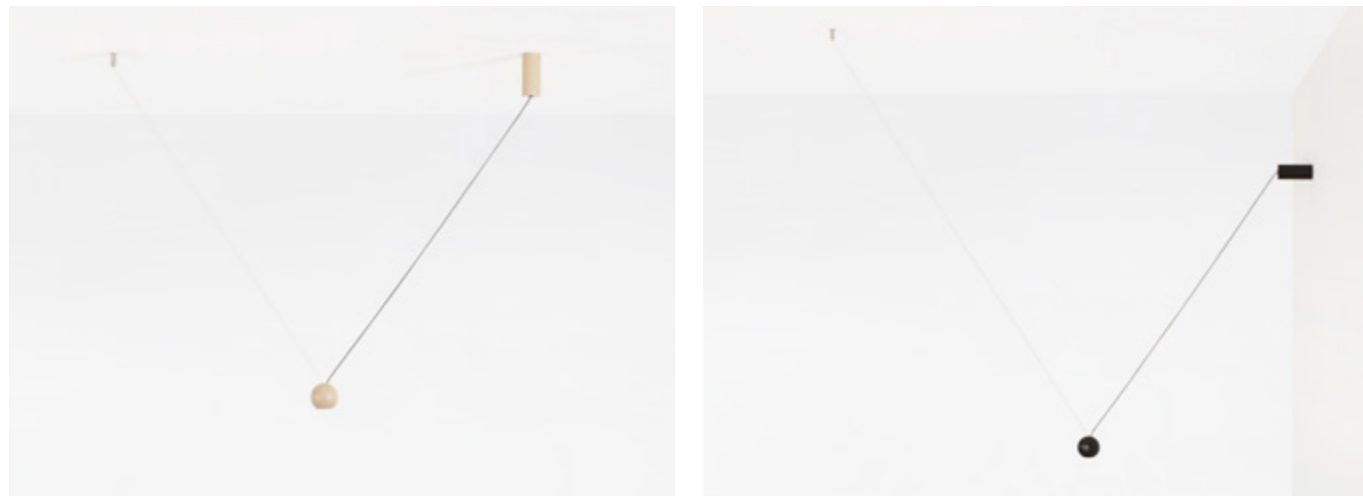

Private residence by @interiorismo\_by\_anaperez



COM 4074-W

LED 6,2W  
(2700K / Ang. 38° >90CRI  
300mA) / 230V  
Typ\* 625 lumens  
Dimmable Triac

COM 4074-M

LED 6,2W  
(3000K / Ang. 38° >90CRI  
300mA) / 230V  
Typ\* 652 lumens  
Dimmable Triac

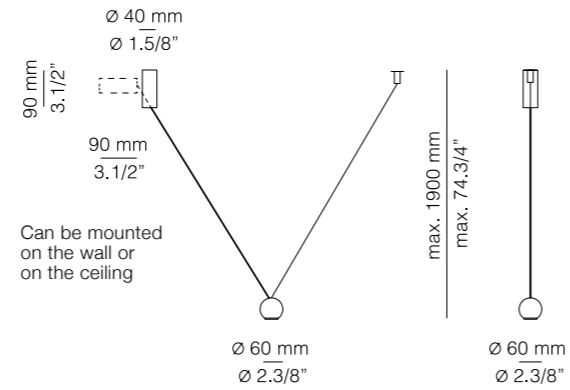

COM R21S2 / With surface canopy

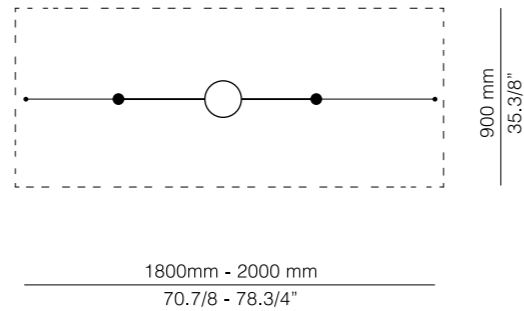
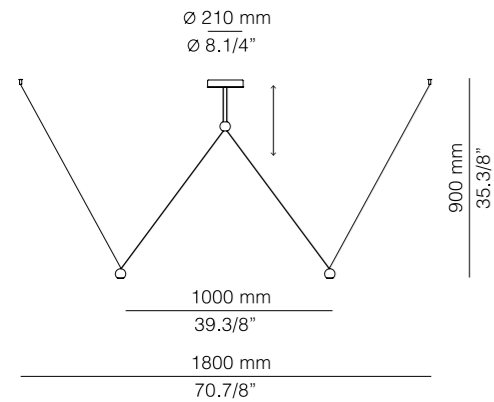

COM R21S4 / With surface canopy

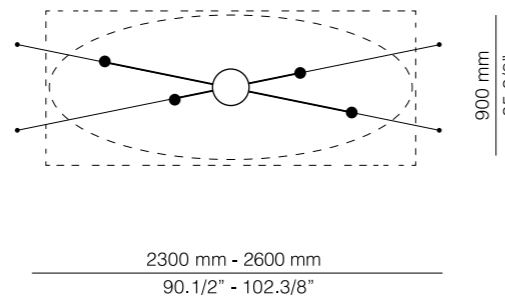
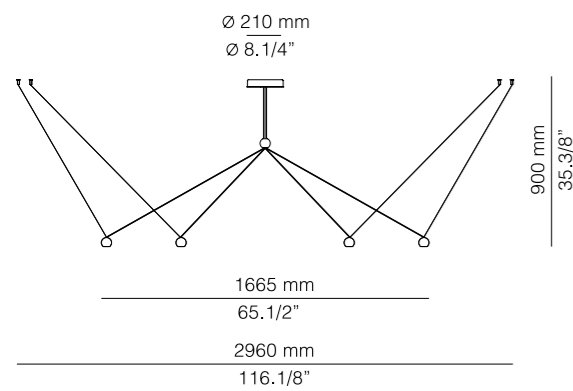

COM 21S6 / With surface canopy

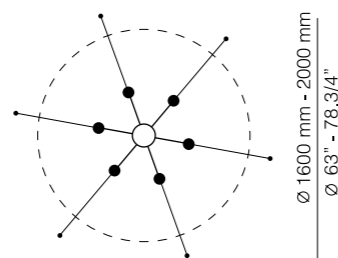
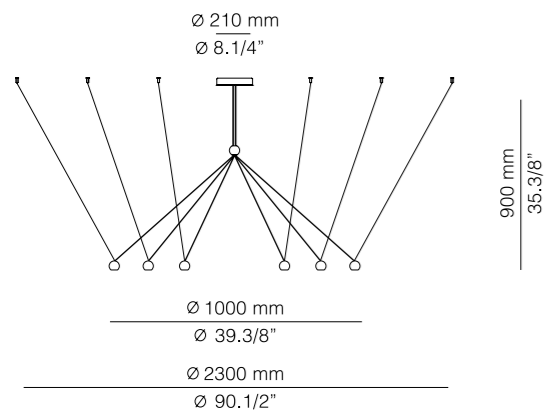

Finishes

- 26 BLACK
- 55 BEIGE
- 59 TERRACOTTA

Additional

We offer custom finishes, sizes, and alternate lamping for projects.

*Photographs may show non-standard products.*





(ENG) Compass has a vision of formal delicacy, whose structure could generate flexible geometries tensioned by small spheres of light. (ESP) Compass tiene una visión de delicadeza formal, cuya estructura puede generar geometrías flexibles tensionadas por las pequeñas esferas de luz.



## COM 4071-W

LED 3W  
 (2700K / Ang. 38° / >90CRI  
 350mA) / 100V - 240V  
 Typ\* 285 lumens  
 Non Dimmable

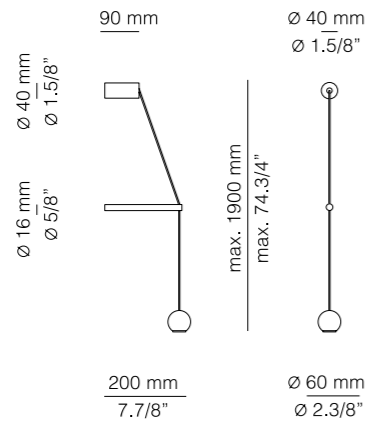

## COM 4071-M

LED 3W  
 (3000K / Ang. 38° / >90CRI  
 350mA) / 100V - 240V  
 Typ\* 367 lumens  
 Non Dimmable

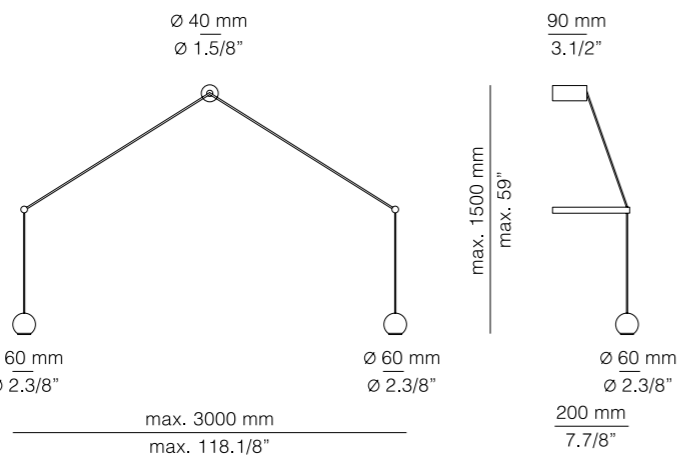

## COM 4072-W

LED 2 x 3W  
 (2700K / Ang. 38° / >90CRI  
 350mA) / 100V - 240V  
 Typ\* 2x285 lumens  
 Non Dimmable

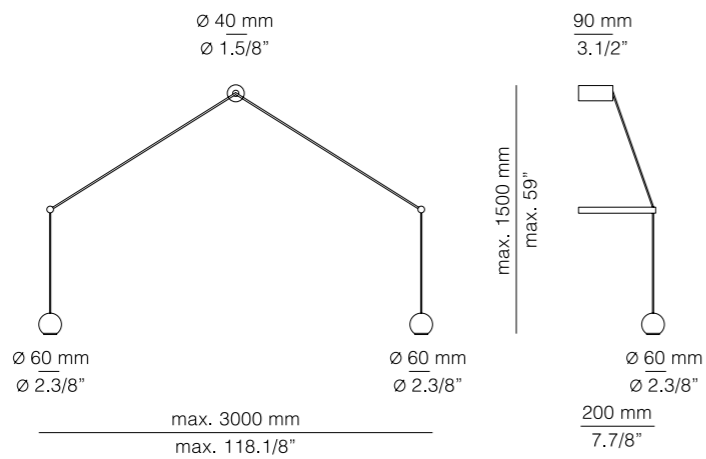

## COM 4072-M

LED 2 x 3W  
 (3000K / Ang. 38° / >90CRI  
 350mA) / 100V - 240V  
 Typ\* 2x367 lumens  
 Non Dimmable

### Finishes

- 26 BLACK
- 55 BEIGE
- 59 TERRACOTTA

### Additional

We offer custom finishes, sizes, and alternate lamping for projects.

*Photographs may show non-standard products.*







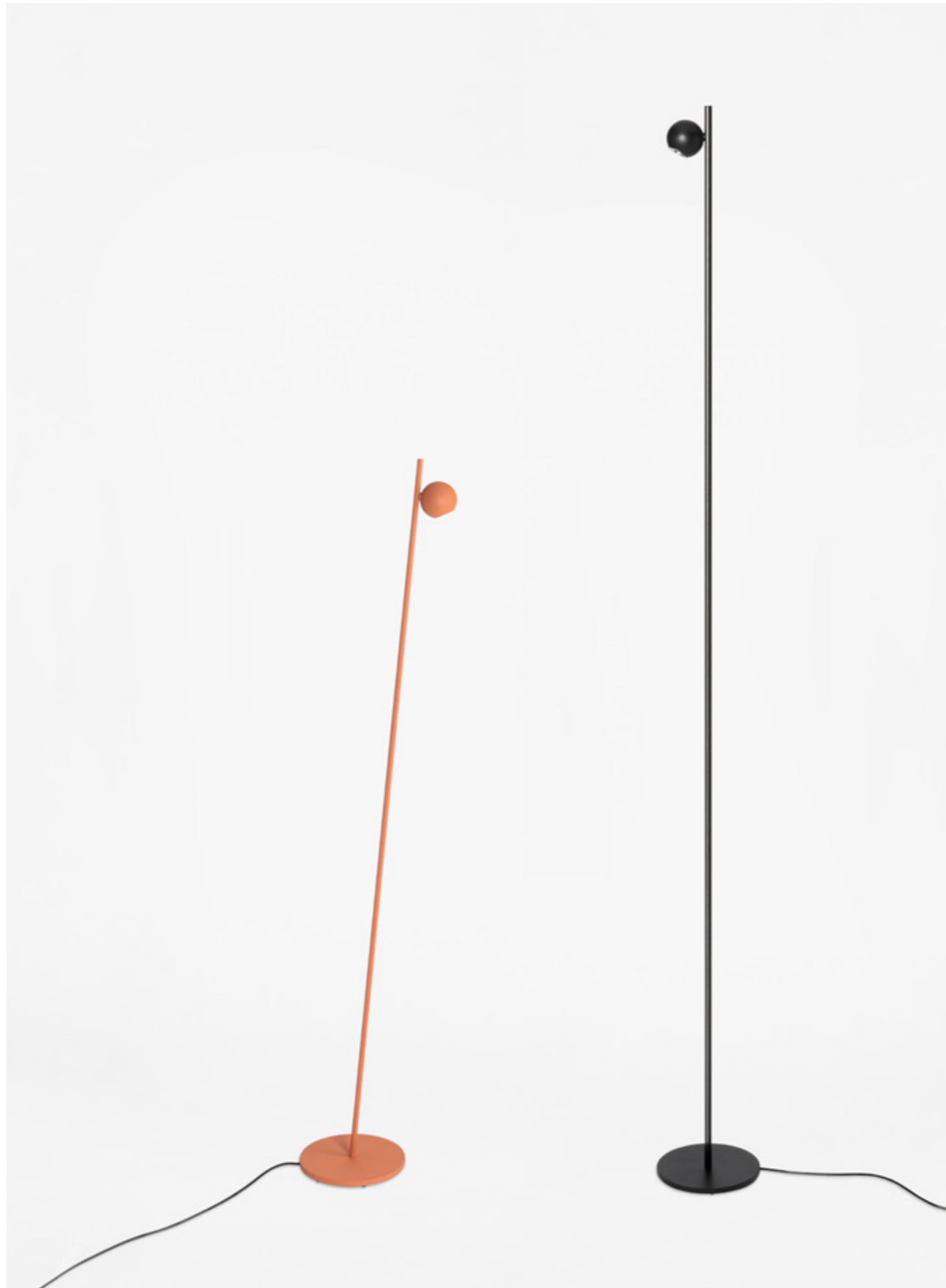

## COM 4077-W

LED 3W  
(2700K / Ang. 38° / >90CRI  
24V) / 100V - 240V  
Typ\* 300 lumens  
Push button dimmer on the cord  
Universal plug

## COM 4077-M

LED 3W  
(3000K / Ang. 38° / >90CRI  
24V) / 100V - 240V  
Typ\* 330 lumens  
Push button dimmer on the cord  
Universal plug

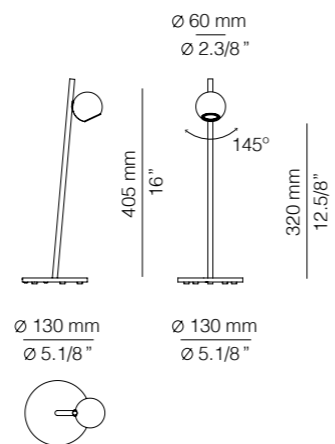

## COM 4078-W

LED 3W  
(2700K / Ang. 38° / >90CRI  
24V) / 100V - 240V  
Typ\* 300 lumens  
Push button dimmer on the cord  
Universal plug

## COM 4078-M

LED 3W  
(3000K / Ang. 38° / >90CRI  
24V) / 100V - 240V  
Typ\* 330 lumens  
Push button dimmer on the cord  
Universal plug

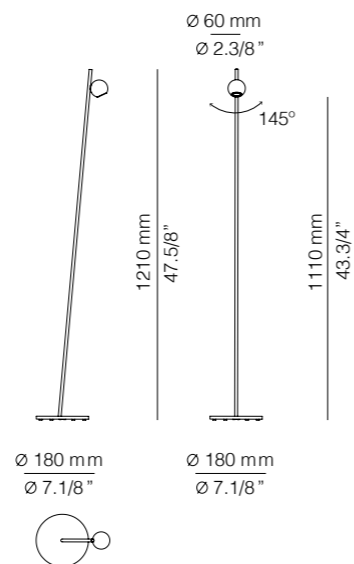

## COM 4079-W

LED 6,2W  
(2700K / Ang. 38° / >90CRI  
300mA) / 100V - 240V  
Typ\* 625 lumens  
Push button dimmer on the cord  
Universal plug

## COM 4079-M

LED 6,2W  
(3000K / Ang. 38° / >90CRI  
300mA) / 100V - 240V  
Typ\* 652 lumens  
Push button dimmer on the cord  
Universal plug

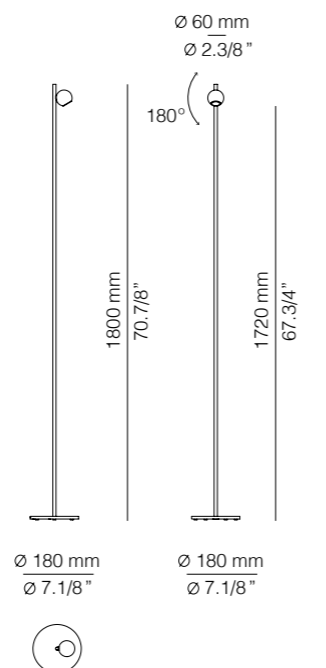

### Finishes

- 26 BLACK
- 55 BEIGE
- 59 TERRACOTTA

### Additional

We offer custom finishes, sizes,  
and alternate lamping for projects.

*Photographs may show non-standard products.*



Private residence by @arnauestudioarquitectura



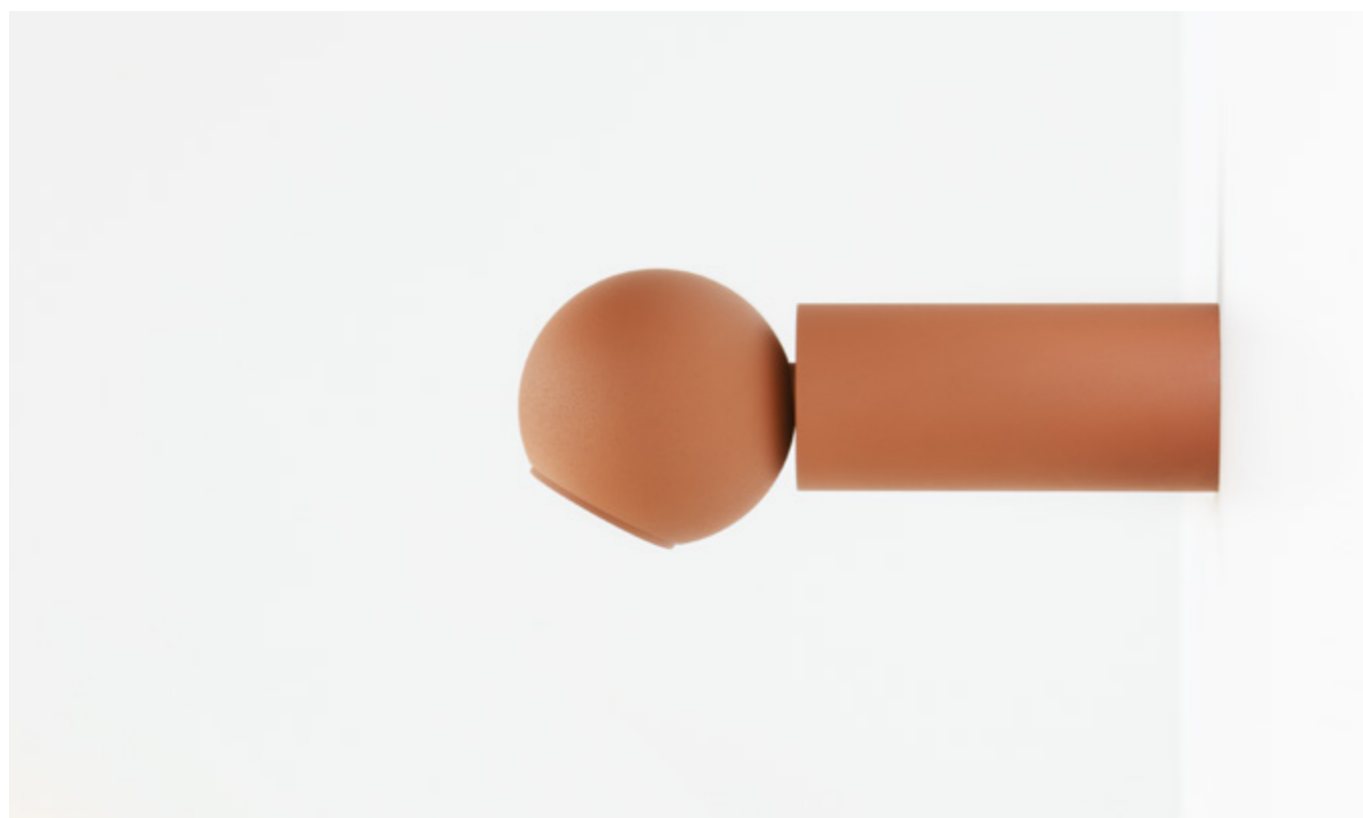

### COM 4070-W

LED 3W  
(2700K / Ang. 38° / >90CRI  
350mA) / 100V - 240V  
Typ\* 285 lumens  
Non Dimmable

### COM 4070-M

LED 3W  
(3000K / Ang. 38° / >90CRI  
350mA) / 100V - 240V  
Typ\* 367 lumens  
Non Dimmable

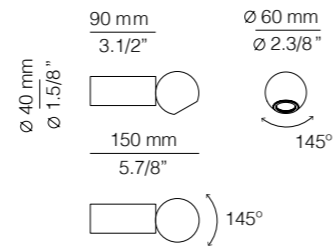

### COM 4073R-W With recessed canopy

LED 3W  
(2700K / Ang. 38° / >90CRI  
350mA) / 230V  
Typ\* 285 lumens  
Remote driver  
Non Dimmable

### COM 4073R-M With recessed canopy

LED 3W  
(3000K / Ang. 38° / >90CRI  
350mA) / 230V  
Typ\* 367 lumens  
Remote driver  
Non Dimmable

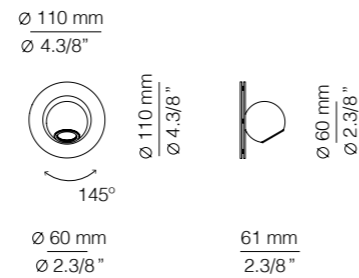

### Finishes

- 26 BLACK
- 55 BEIGE
- 59 TERRACOTTA

### Additional

We offer custom finishes, sizes, and alternate lamping for projects.

*Photographs may show non-standard products.*



### COM 4073S Projects only

Contract version requires minimum quantity

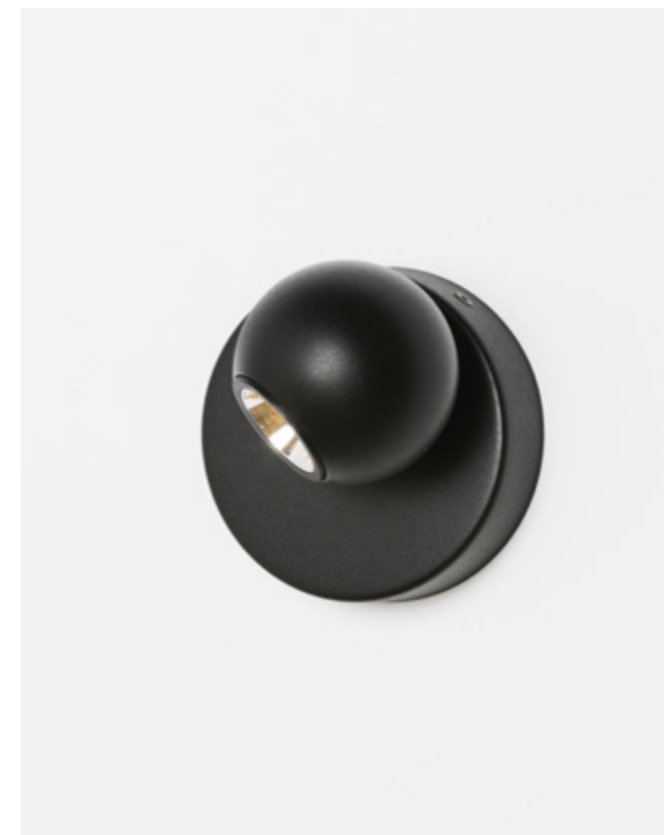
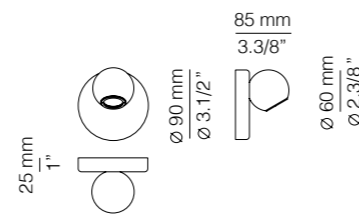

# TECHNICAL FEATURES

## SYMBOLS / SÍMBOLOS

**CE** (ENG) Products manufactured according to the European safety and electromagnetic standards (EN 60598-1 and EN 60598-2-1). (ESP) Productos fabricados acorde con las directrices de seguridad y emisiones electromagnéticas según la legislación europea aplicable (EN 60598-1 y EN 60598-2-1).

**650°**  
**850°**  
**960°**  
**VI** (ENG) This product has passed successfully the test of the glow wire test at this temperature (standards NF C 20-455 and EN-60-598-1). (ESP) Productos que han superado con éxito el ensayo de hilo incandescente a la temperatura indicada (normas NF C 20-455 y EN-60-598-1).

**IP**  
**20** (ENG) Product protected against the penetration of solid bodies equal or bigger than 12 mm and against the access with a finger. No protection to the water (standard NF C 20 010). (ESP) Producto protegido contra la penetración de cuerpos sólidos de diámetro superior o igual a 12 mm. No accesible con los dedos. Sin protección al agua (norma NF C 20 010).

**IP**  
**65** (ENG) Totally protected against the entry of dust and against jetting water in all directions. (ESP) Totalmente estanco al polvo y protegido contra chorros de agua en todas las direcciones.

**⊕** (ENG) Basic insulation with earth wire (products class I). (ESP) Aislamiento básico con toma de tierra (productos de clase I).

**□** (ENG) Reinforced or double insulation, without earth wire (products class II). (ESP) Aislamiento reforzado o doble, sin toma de tierra (productos de clase II).

**||||** (ENG) Dimmer. (ESP) Regulador.

**Typ\*** (ENG) Typical performance (average). (ESP) Rendimiento típico (promedio).

**Ang.(x)°** (ENG) Beam angle. (ESP) Ángulo de apertura.

## FINISHES / ACABADOS

- 26 BLACK MATT / NEGRO MATE
- 74 WHITE SATIN, RAL 9002  
BLANCO LACADO SATINADO, RAL 9002
- 91 NUDE / ROSA PÁLIDO / NCS S 0804-Y90R
- 55 BEIGE, RAL 1019 / BEIGE, RAL 1019
- 59 TERRACOTTA NCS S 4030-Y80R  
TERRACOTA NCS S 4030-Y80R
- 88 GREY STONE, RAL 7039  
GRIS PIEDRA, RAL 7039
- 89 PALE GREEN, RAL 7033  
VERDE PÁLIDO, RAL 7033
- 96 BLACK ANTHRACITE RAL 7021  
NEGRO ANTRACITA, RAL 7021
- 61 24 CARAT SATIN GOLD  
ORO 24Q SATINADO

## PHOTOMETRICS / CURVAS FOTOMÉTRICAS

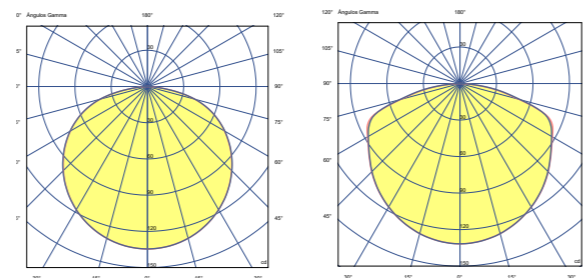
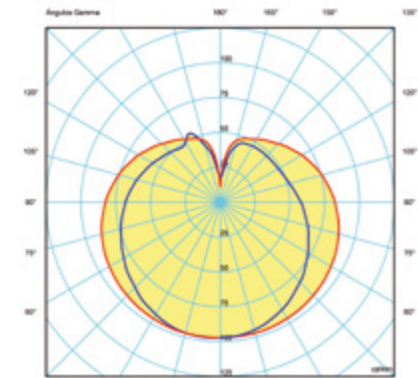

Available at / Disponibles en  
[www.estiluz.com/en/downloads](http://www.estiluz.com/en/downloads)  
[www.estiluz.com/es/downloads](http://www.estiluz.com/es/downloads)

## RESPONSIBILITY FOR THE PLANET / RESPONSABILIDAD CON EL PLANETA

(ENG) Responsibility for the planet is part of our corporate philosophy. Estiluz is aware of the impact of our daily activities and has formed a committee to create a culture that embraces all the processes of sustainability for our environment. (ESP) La responsabilidad con el planeta forma parte de nuestra filosofía corporativa. Conscientes del impacto de nuestras actividades diarias en el entorno, hemos formado un comité para crear una cultura que abarque todos los procesos de sostenibilidad.

More at / Más información  
[www.estiluz.com](http://www.estiluz.com)



## MODIFICATIONS / MODIFICACIONES

(ENG) Estiluz reserves the right to modify or discontinue, without previous notice, products in the catalog. Please check our web for current product availability and specifications. Lumens on LED's indicate the lumen output without diffuser.

(ESP) Estiluz se reserva el derecho a modificar o anular, sin previo aviso, productos de este catálogo. Por favor visite nuestra web para conocer los productos y especificaciones actuales. Los lúmenes indicados son de salida, sin difusor.

## COMMENTS / OBSERVACIONES

All ESTILUZ, S.A. products are designed and manufactured to keep customers satisfied, consequently please note the following:

1. Due to the high quality of our finishes, we recommend using a soft dry polish cloth for cleaning, avoiding the use of special cleaning products that could damage the finish.
2. Do not use lamps of a higher power than indicated.
3. All models are patent protected.
4. Conformity Certificates and technical information of our products are available upon request.

Los productos de ESTILUZ, S.A han sido diseñados y fabricados para satisfacer al máximo a nuestros clientes, debiendo por ello informarles de:

1. Dada la alta calidad de nuestros acabados, aconsejamos efectuar la limpieza exclusivamente con una gamuza seca, evitando el uso de productos especiales que podrían dañar la superficie.
2. No deberán utilizarse bombillas de potencia superior a la indicada.
3. Modelos protegidos por el Registro de la Propiedad Industrial.
4. Certificados de Conformidad e información técnica de nuestros productos disponibles bajo consulta.

**ESTILUZ (Headquarters)** / Carretera d'Ogassa s/n  
E-17860 St Joan de les Abadesses (Girona) Spain  
T + 34 972 720 125 / [estiluz@estiluz.com](mailto:estiluz@estiluz.com)

**ESTILUZ Inc. USA & CANADA** / 330 West 38th St. Suite 710  
New York, NY 10018 USA /  
T +1 (646) 454 - 1285 / [info@estiluzusa.com](mailto:info@estiluzusa.com)

[www.estiluz.com](http://www.estiluz.com)

