

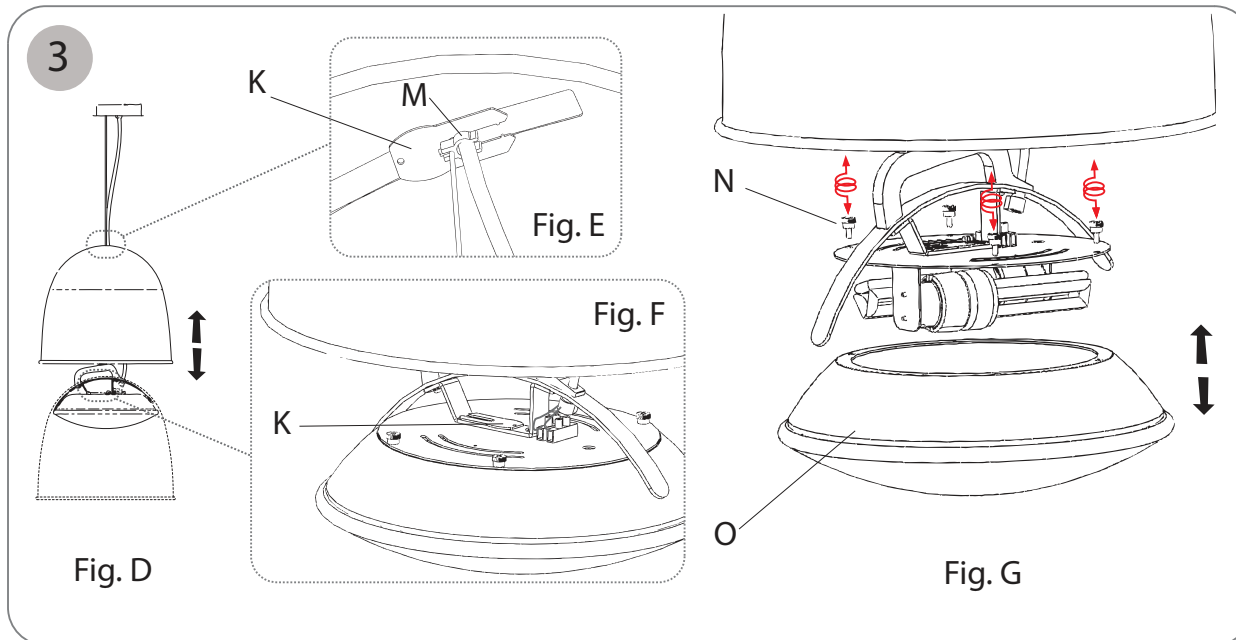

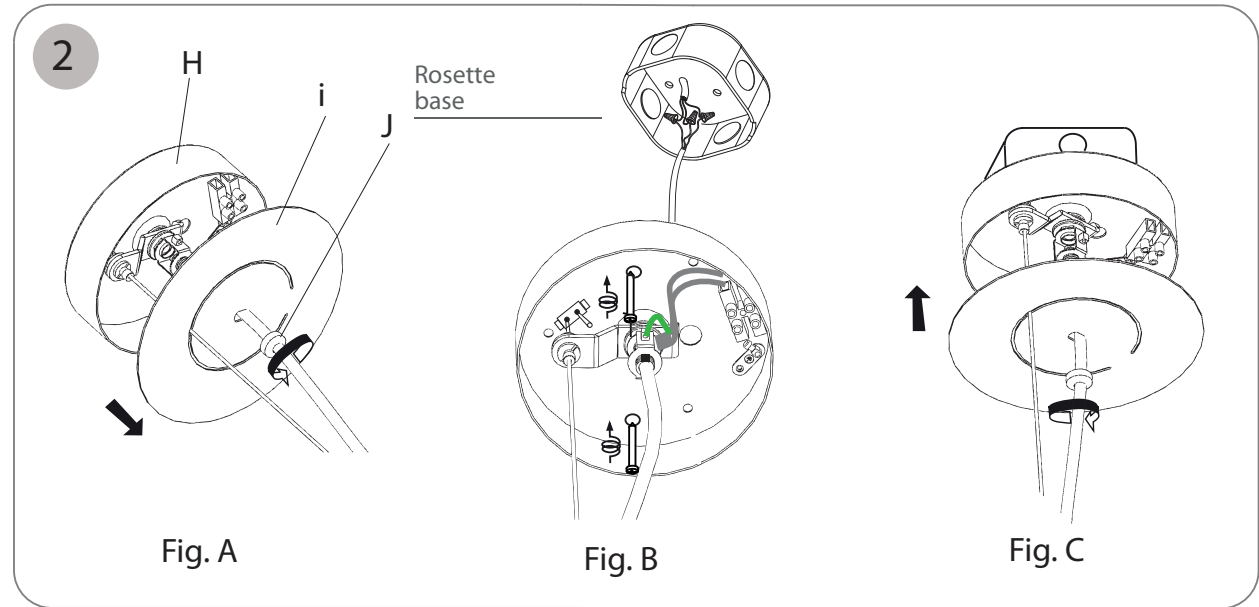

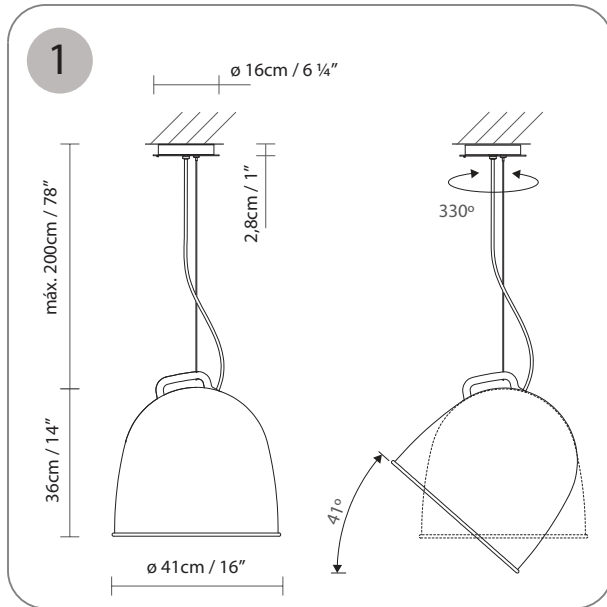

1. General dimensions and turn movements of the lamp.
2. Unscrew the stopper (J) and remove the cover (i) (Figure A). Fix the support (H) to the ceiling using the dowels and lag screws (figure B). Then make the connection and place the cover (i) in position, securing it with the stopper (J) (Figure C).
3. In order to change the bulb it is necessary to raise the shade (figure D) over the cable guide (M) and place the clip (K) (Figure E). In Figure F we find the clip (K). Turn the three bindings of the diffuser (N) outwards, holding the diffuser (O), which is left loose (Figure G). Switch the bulb and perform the steps from # 3 the other way around.



1. General dimensions and turn movements of the lamp.
  2. Unscrew the stopper (J) and remove the cover (i) (Figure A). Fix the support (H) to the ceiling using the dowels and lag screws (figure B). Then make the connection and place the cover (i) in position, securing it with the stopper (J) (Figure C).
  3. In order to change the bulb it is necessary to raise the shade (figure D) over the cable guide (M) and place the clip (K) (Figure E). In Figure F we find the clip (K). Unscrew the 4 screws (N), holding the diffuser (O), which comes loose (Figure G). Change the bulb and complete the steps from No. 3 in reverse order.
- \* When the light source is LED there is no Step 3.

#### Consumer information:

- Lamps without the IP mark are classed as IP20 and are designed for general interior use, except wet areas (bathrooms, etc.)
- Lamps with the IP mark are designed for exterior use and in wet areas. (E.g. IP54)
- They offer guaranteed protection to people and animals against electrical discharge:
  - Class I: through single electrical insulation and an earthing conductor once correctly connected.
  -  • Class II: through double electrical insulation.
  -  • Class III: these kinds of lamps should be connected at very low voltage levels (generally 12V); therefore there is no risk.
-  • Lamps with this symbol, or without any symbols, can be mounted directly onto normally inflammable surfaces.
-  • Lamps with this symbol cannot be mounted directly onto normally inflammable surfaces.
- The safety of this lamp is guaranteed by using a maximum wattage bulb that does not exceed the figure displayed visibly on the lamp.
-  • The product cannot be treated like conventional domestic waste; it must be taken to the corresponding recycling point for electrical and electronic equipment.

#### Assembly instructions

**B.lux**

B.LUX S.A.  
Pol. Ind. Okamika, pab. 1  
48289 Gizaburuaga (Bizkaia) Spain  
T. (+34) 94 682 72 72  
F. (+34) 94 682 49 02  
info@grupoblux.com  
www.grupoblux.com