

**1**

S CURRENT SUPPLY

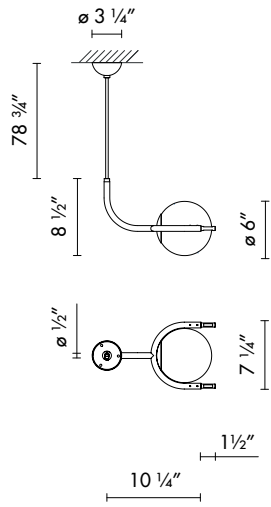

S 90°H CURRENT SUPPLY

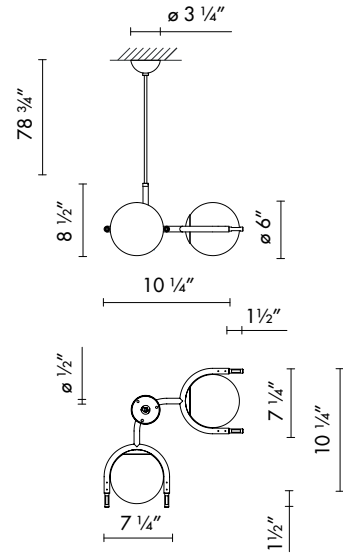

C/W 90°H CURRENT SUPPLY

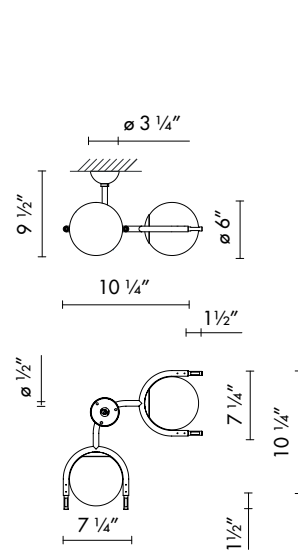

C/W CURRENT SUPPLY

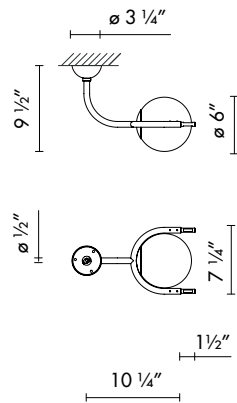

C/W 90°V CURRENT SUPPLY

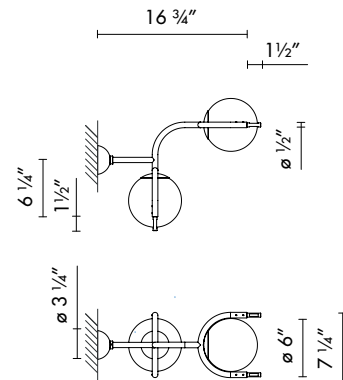

**2**

S CURRENT SUPPLY / S 90°H CURRENT SUPPLY

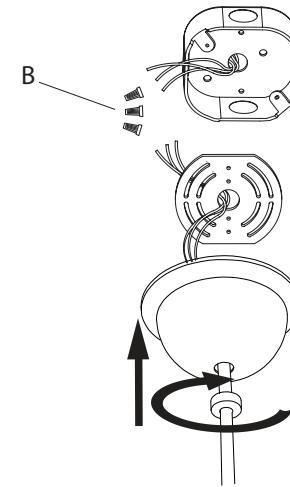

C/W CURRENT SUPPLY / C/W 90°H CURRENT SUPPLY /  
 C/W 90°V CURRENT SUPPLY

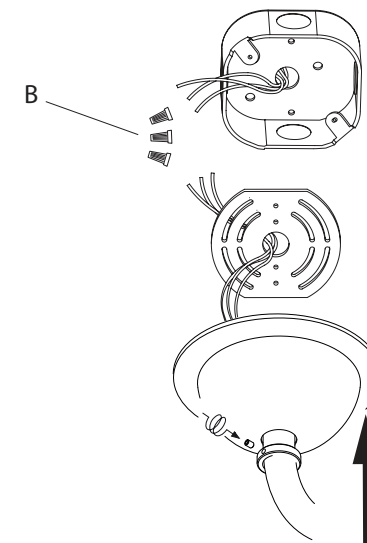

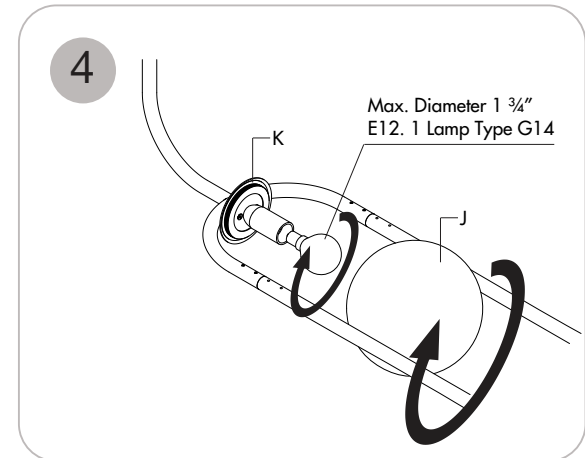
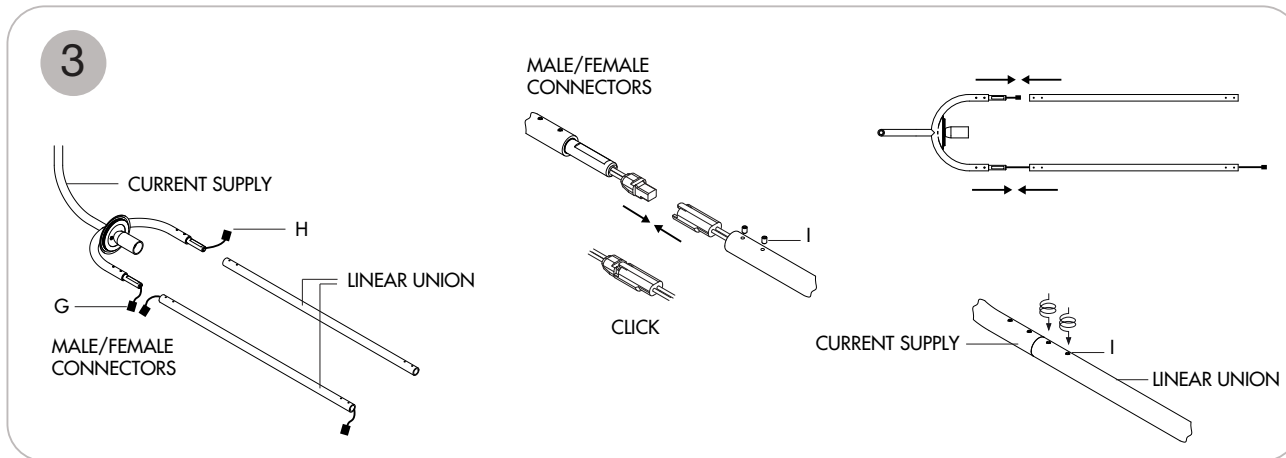

1. General dimensions of the “Current Supply” accessories for the C\_Ball System.
2. Make the connections and secure the lamp (B) using two studs.
3. Connections: The “Current Supply” accessories are prepared with a male connector on each end (G and H). Attach just one connection line in the assembly, leaving one of the ends unconnected (H). To make the electrical connection between the different parts, snap the male and female connectors together until you hear a click. Assemble the “Linear Union” tubes into the tubes on the “Current Supply” accessory and tighten the bolts (I).
4. To assemble the bulb and glass (J), thread the E14 bulb into the bulb socket and thread the glass shade into the metal thread (K).

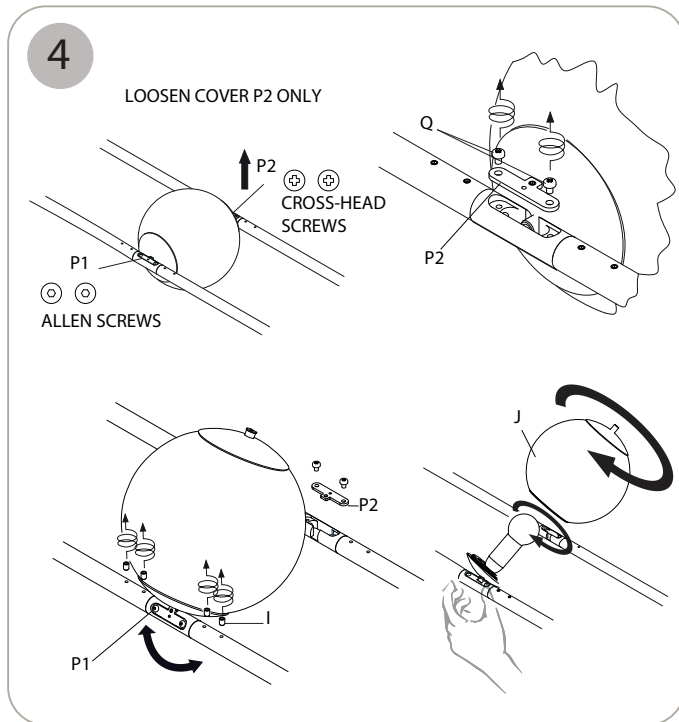
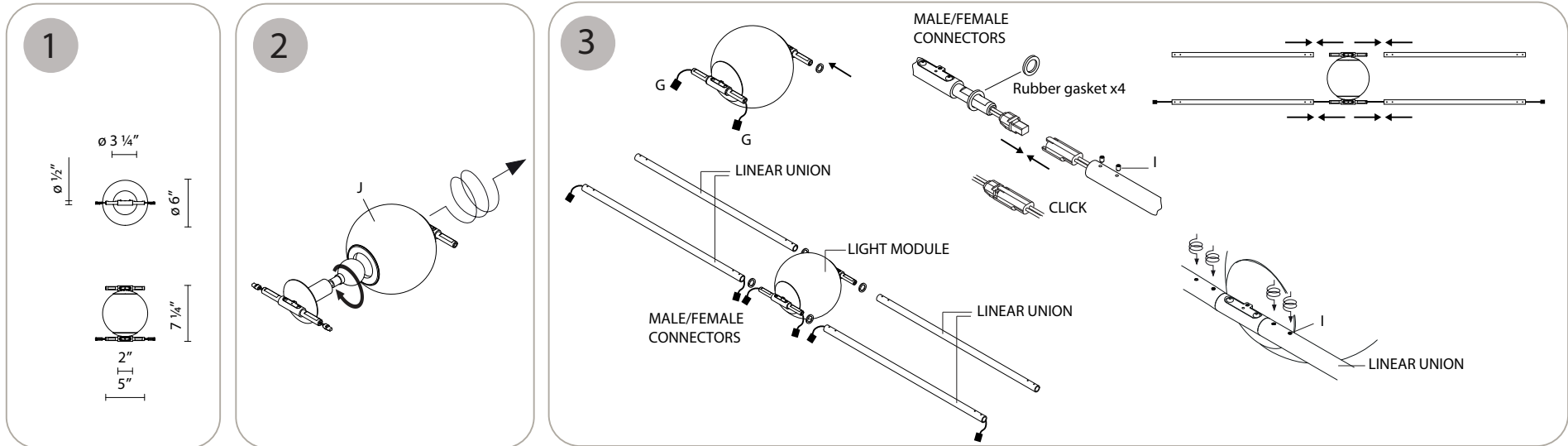

1. General dimensions of the "Light Module" accessory for the C\_Ball System.

2. To install the bulb, hold the piece by the part with the cables and loosen the glass. Thread the E14 bulb into the bulb socket and tighten the glass once more.

3. Connections: The "Light Module" accessories are prepared with a male connector on each end (G). To attach it to the "Linear Union" tubes, first connect the electrical wire in the assembly, snapping the male and female connectors together with a click. Then, assemble the tubes on both accessories and tighten the bolts (I).

4. To replace the bulb: Covers (P1) and (P2) are attached with different screws. Cover P1 uses Allen screws, while cover P2 uses cross-head screws. To replace the bulb, only cover P2 has to be removed by loosening the cross-head screws (Q). Then loosen the four bolts (I) that are on either side of the cover (P1). Twist the "Light Module" about this axis, hold the part by (P1) and unthread the glass (J). Screw in an E14 bulb, screw in the glass (J), twist the "Light Module" back to its initial position and screw in cover (P2) again.

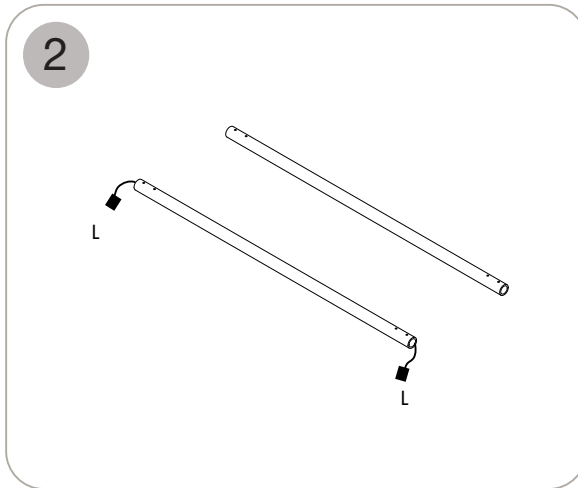
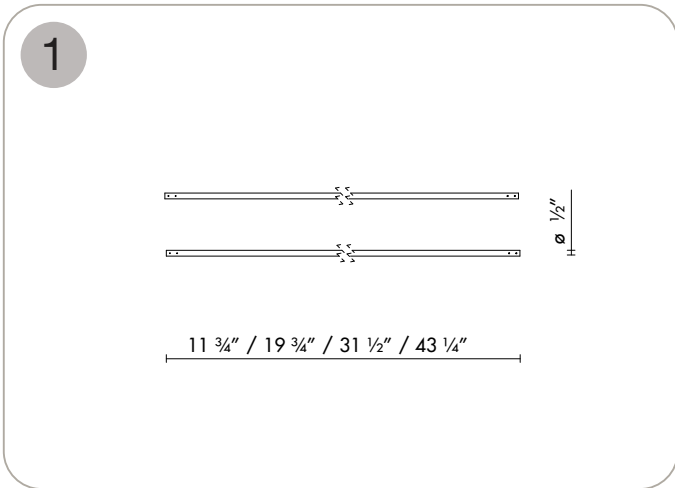

1. General dimensions of the "Linear Union" accessories for the C\_Ball System.
2. The "Linear Union" accessory comes with two tubes. One of them has a female connector on each end (L).
3. To attach it to other accessories, first connect the electrical wire in the assembly, snapping the male and female connectors together with a click. Then, assemble the tubes and tighten the bolts (I).

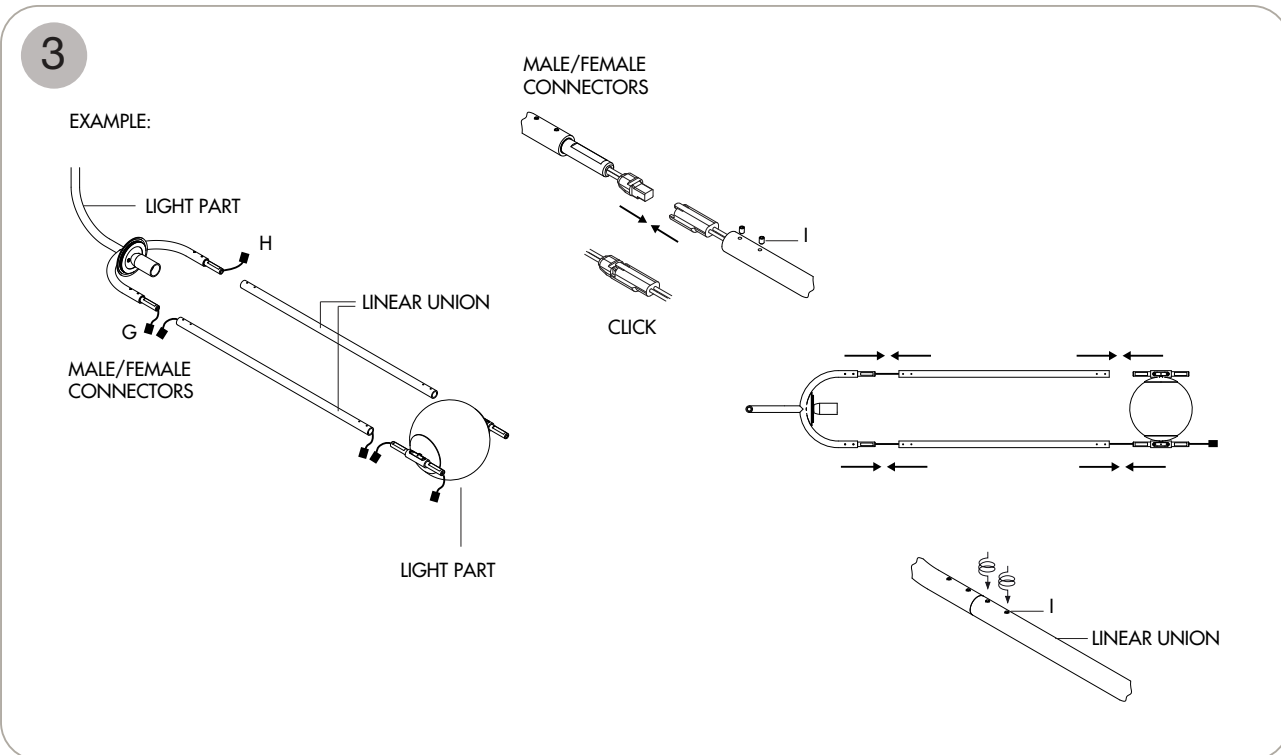

1

S SINGLE SUSPENSION

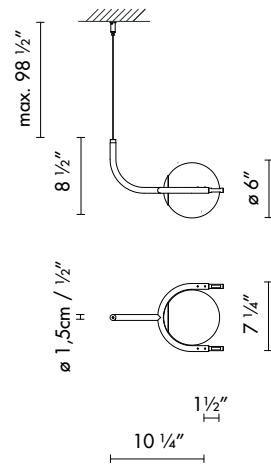

S 90°H SINGLE SUSPENSION

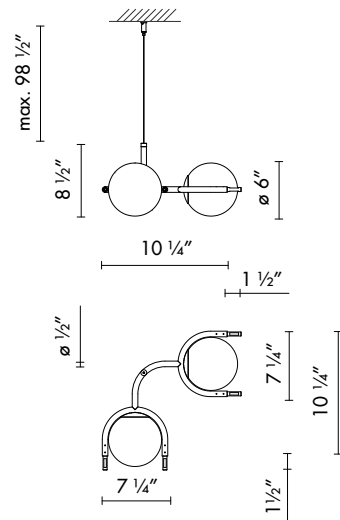

2

2.1

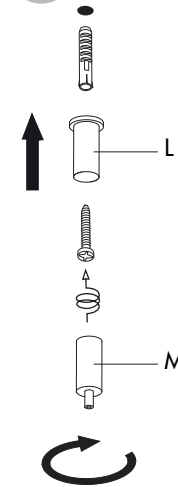

2.2

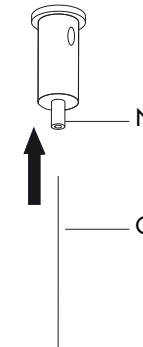

2.3

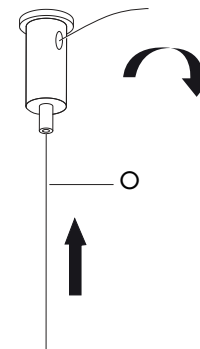

2.4

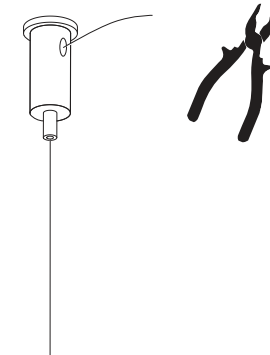

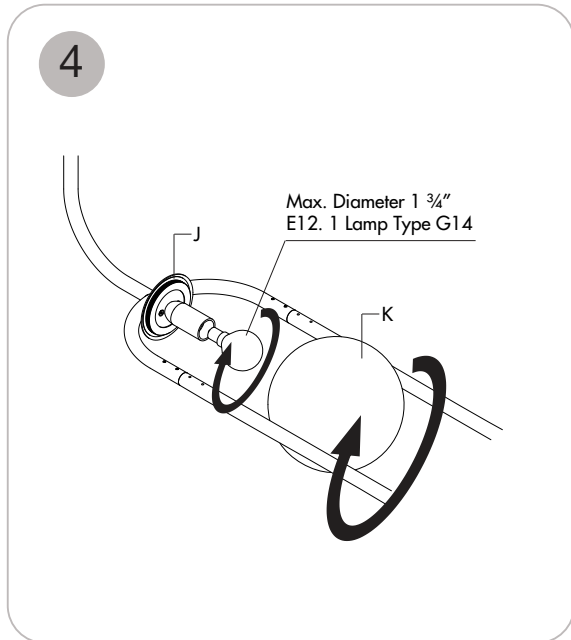
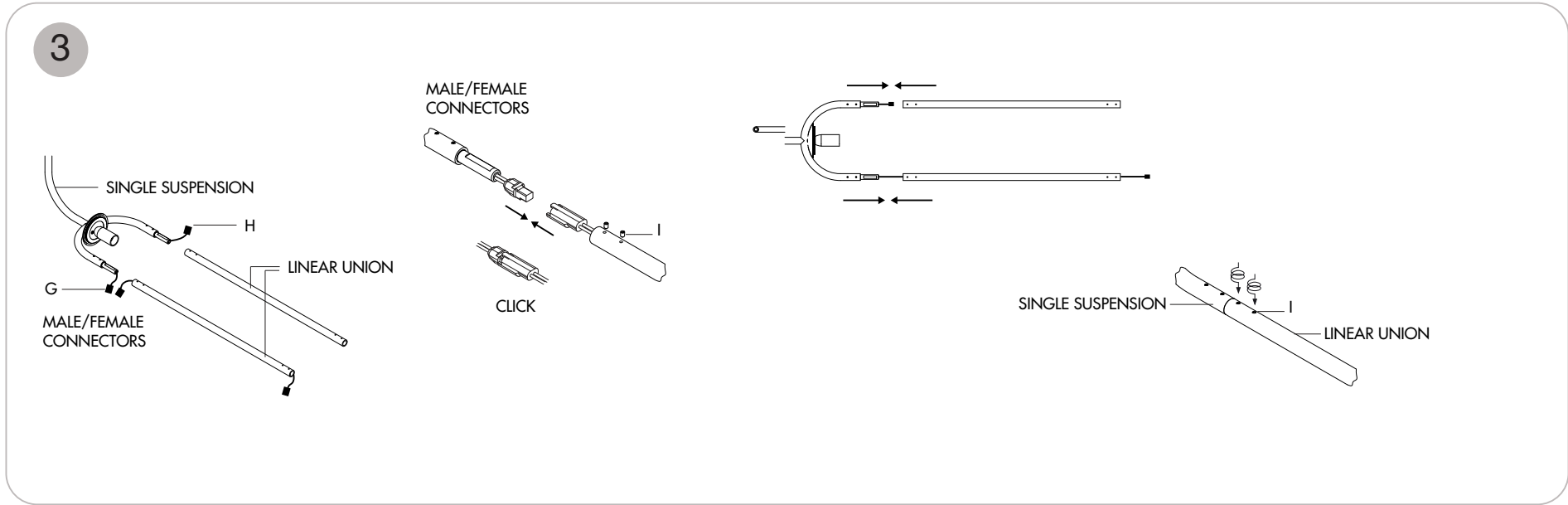



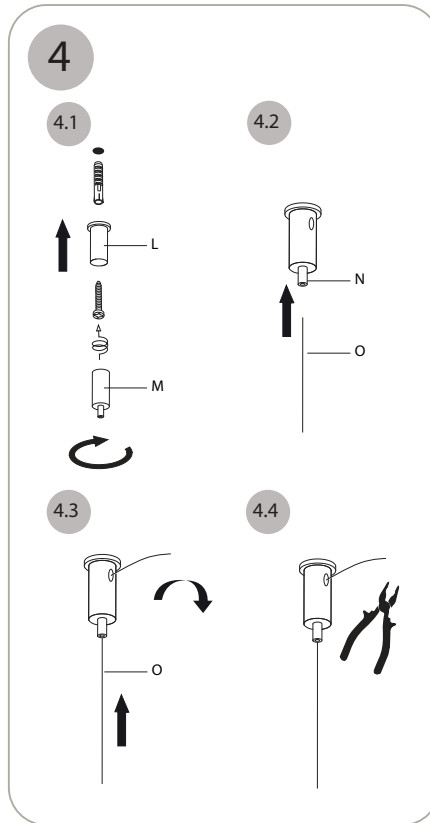
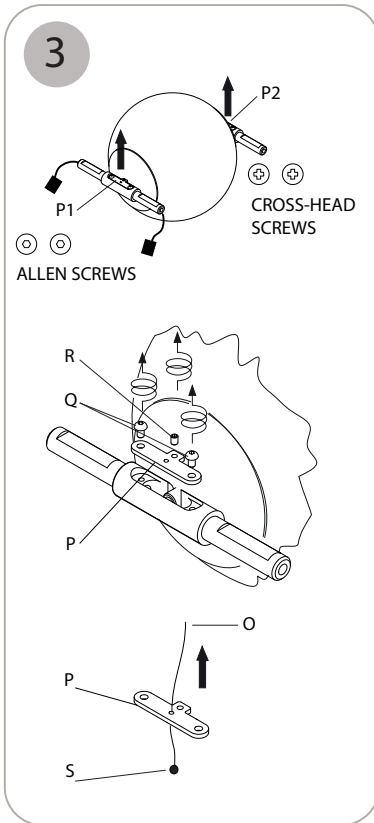
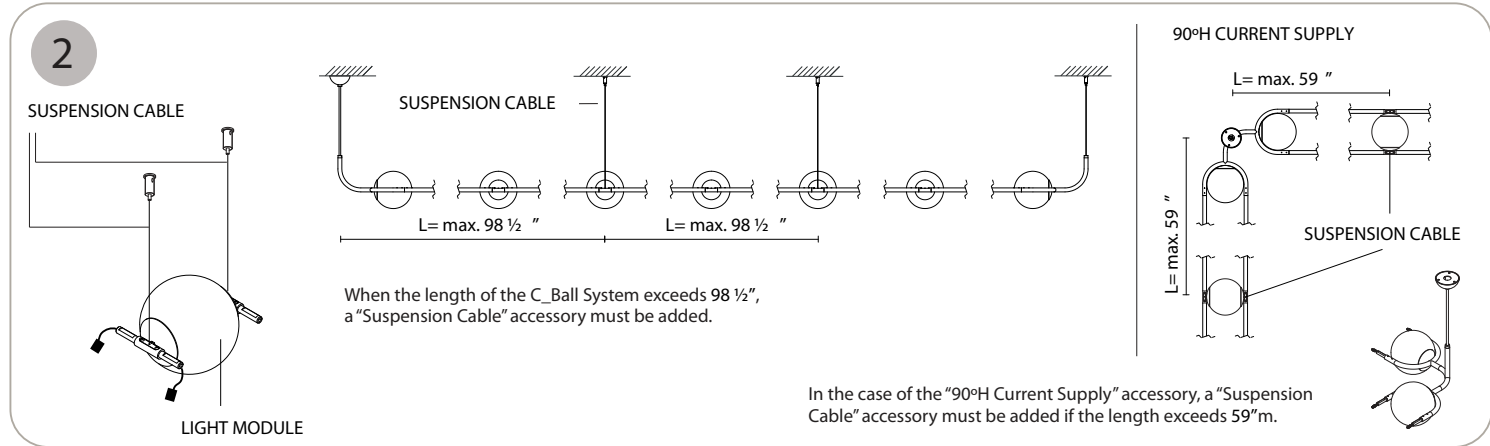
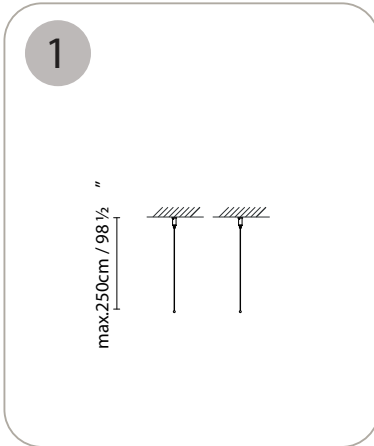

1. General dimensions of the “C\_Ball System Single Suspension” accessories.
2. Screw the base plate (L) to the ceiling. Thread the tensor (M) to the base plate (L). Tighten part (N) on the tensor and route the steel wire (O) through the tensor, pulling it out the side. Tense the cable to the desired length and cut the excess.
3. Connections: The “Single Suspension” accessories are prepared with a male connector on each end (G and H). Attach just one connection line in the assembly, leaving one of the ends unconnected (H). To make the electrical connection between the different parts, snap the male and female connectors together until you hear a click. Assemble the “Linear Union” tubes into the tubes on the “Single Suspension” accessory and tighten the bolts (I).
4. To assemble the bulb and glass (J), thread the E14 bulb into the bulb socket and thread the glass shade into the metal thread (K).



1. General dimensions of the "Suspension Cable" accessory for the C\_Ball System.
2. The "Suspension Cable" accessory is two steel wires with retainers that can be added to the "Light Module" accessory and specify intermediate attachment points in the ceiling in a C\_Ball System line. When the length of the C\_Ball System exceeds 2.50m, a "Suspension Cable" accessory must be added. In the case of the "90°H Current Supply" accessory, a "Suspension Cable" accessory must be added if the length exceeds 1.25m.
3. To add the steel wires to the "Light Module", the two covers (P1 and P2) have to be removed by loosening the screws (Q) and the bolts (R). Thread the steel wire (O) through the hole on the cover (P) and reattach the cover such that the steel wire ball (S) is inside it.
4. Screw the base plate (L) to the ceiling. Thread the tensor (M) to the base plate (L). Tighten part (N) on the tensor and route the steel wire (O) through the tensor (M), pulling it out the side. Tense the cable as desired and cut the excess.

#### Consumer information:

- Lamps without the IP mark are classed as IP20 and are designed for general interior use, except wet areas (bathrooms, etc.)
- Lamps with the IP mark are designed for exterior use and in wet areas. (E.g. IP54)
- They offer guaranteed protection to people and animals against electrical discharge:
  - Class I: through single electrical insulation and an earthing conductor once correctly connected.
  -  • Class II: through double electrical insulation.
  -  • Class III: these kinds of lamps should be connected at very low voltage levels (generally 12V); therefore there is no risk.
-  • Lamps with this symbol, or without any symbols, can be mounted directly onto normally inflammable surfaces.
-  • Lamps with this symbol cannot be mounted directly onto normally inflammable surfaces.
- The safety of this lamp is guaranteed by using a maximum wattage bulb that does not exceed the figure displayed visibly on the lamp.
-  • The product cannot be treated like conventional domestic waste; it must be taken to the corresponding recycling point for electrical and electronic equipment.

#### Assembly instructions

**B.lux**

B.LUX S.A.

Pol. Ind. Okamika, pab. 1  
48289 Gizaburuaga (Bizkaia) Spain  
T. (+34) 94 682 72 72  
F. (+34) 94 682 49 02  
info@grupoblux.com  
www.grupoblux.com