



# PUNTO Y COMA PREMIUM

*Technical Information*

**nomon**  
JEWELRY FOR HOME

# PUNTO Y COMA PREMIUM

Technical Information

nomon  
JEWELRY FOR HOME

## TECHNICAL DRAWINGS

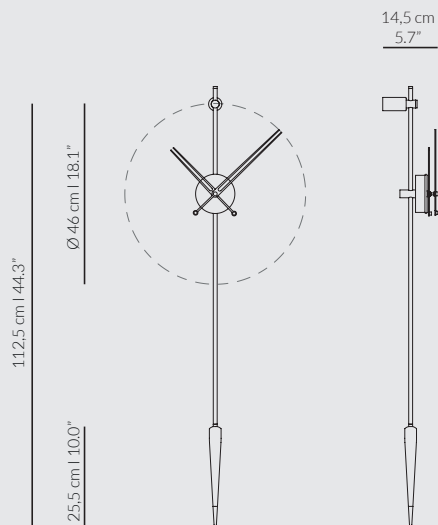

## MATERIALS

### BOX / CAJA

Walnut or oak wood / *Madera de nogal o roble*

### HANDS / AGUJAS

Walnut wood and polished brass / *Madera de nogal y latón pulido*

Oak wood and black finished brass / *Madera de roble y latón acabado negro*

### PENDULUM / PÉNDULO

Walnut wood and polished brass / *Madera de nogal y latón pulido*

Oak wood and black finished brass / *Madera de roble y latón acabado negro*

### MECHANISM / MECANISMO

UTS German / *UTS alemán*



POLISHED  
BRASS



WALNUT  
WOOD



BRASS FINISH  
GLASS FIBER



OAK  
WOOD



BLACK  
FINISH BRASS

## PACKAGING

Weight / *Peso*: 1.70 Kg | 1,70 Kg

Net weight / *Peso neto*: 0.60 Kg | 0,60 Kg

Volumetric weight / *Peso volumétrica*: 3.80 Kg | 3,80 Kg

Dimensions / *Dimensiones*: 7.5" x 49.2" x 3.1" | 19cm x 125cm x 8cm

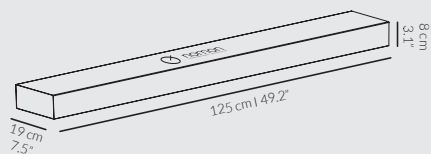

Assembly video / *Vídeo de montaje* :

[www.nomon.es](http://www.nomon.es)