



lzf

**WOOD** touched by **LIGHT**

Since 1994





**WOOD**

TOUCHED BY

**LIGHT**

lzf

---

# HISTORY



---

At LZF, we have made a conscious and deliberate choice to manufacture our lamps at home in Valencia, Spain. This is a region with an exceptional wealth of talent and expertise. By working locally, we enjoy much greater control and flexibility over the design and creation of every LZF lamp.

It is now more than twenty-five years since the inception of LZF as a lighting brand. Today, we are a business that thrives on time-honoured craft and manufacturing techniques, complemented by modern innovation and technology. We are thrilled to work with an eclectic roster of accomplished designers and diligent craftspeople. As a collective result, LZF has received more than thirty-five national and international awards, most notably Spain's Premios Nacionales de Innovación y de Diseño 2020 (the National Innovation and Design Award 2020) and the Premio Nacional de Artesanía in 2011 (the Spanish National Craftsmanship Award).

As a family business, LZF is always on the side of the client and working tirelessly to meet their needs. We endeavour to provide our clients with a warm, friendly, and professional level of service. As artisans, artists, designers, innovators, and technicians, we put our heart and soul into our work. We stand behind everything we do.

At LZF, we approach every aspect of our business with responsibility and accountability. We believe in the principle of less but better. We are not guided by trends: our collection is permanent and our handmade lamps are built to last. We know that any pursuit of keeping costs low serves no honest or useful purpose. In a world of fast design, mass consumption, and harmful waste, we believe in the absolute importance of manufacturing locally, in championing tradition, in a circular economy, and in promoting sustainability.

Spain is a country that is proudly dependent on its local talent and manufacturing: this is part of our nature. With increasing globalisation, we must work to regenerate the industrial fabric on which many generations of tradition have been built. LZF recognises the continual need to support our local business endeavours, and we do so with complete commitment and a willingness to collaborate.

LZF, proudly handmade in Spain.

---

# NATURAL WOOD MEANS NATURAL LIGHT

---

  
Timberlite™



The mark of  
responsible forestry

Wood is a noble material and has been part of our DNA since our beginnings. All LZF lamps are handmade from FSC natural wood veneer, ensuring their origin from controlled forests and guaranteeing our sustainability and environmental commitment. LZF lamps' wood veneers are treated with a technique patented by LZF, called Timberlite®, that allows this fragile material to become flexible and resistant without the need of any chemical processes. Knots and other elements of wood are a natural occurrence and form part of the feel and design of the material. As a living material our veneers will age with time, changing as you change, accompanying you with their richness during a whole lifetime.

**ON**

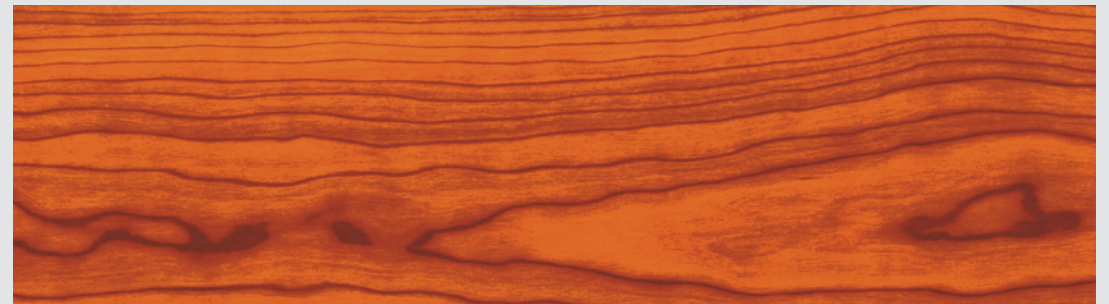

**OFF**



---

# CONTENTS

---

**INDEX 10**

---

**LATEST COLLECTION 14**

Dune	16
Estela	20
Eris	24
Tomo	30
Lens	34
Oh!Line	38
I-Line	42
Maruja	46
Suns	50

---

**THE COLLECTION 54**

Agatha	56
Air	62
Banga	66
Black Note	70
Candelabro	84
Carambola	90
Mini Chou	94
Chou	98
Cuad	102
Dandelion	106
Domo	110
Escape	114
Gea & Cosmos	118
Guijarro	126
Hi-Collar	130
I-Club	134
Lens	142
Link	148
Lola	156

---

MiniMikado	170
New Wave	176
Nut	180
Orbit	184
Pleg	188
Pod & Poppy	192
Raindrop	196
Saturnia	200
Spiro	204
Stitches	210
Swirl	214
Totem	218
Thesis	222
X-Club	230

---

**LIFE SIZE 234**

Smelly Fant	236
The Walking Fish	240
Big Bird	244
Koi & Kogoi	252

---

**NATURAL TIMBER VENEER 258**

---

**METAL FINISHES 262**

---

**DESIGNERS 264**

---

**CREDITS 267**

# INDEX

## 1

### SUSPENSION



**AGATHA** 56  
Suspension



**AGATHA BALL** 56  
Suspension



**BANGA** 66  
Suspension



**MARUJA** 46  
Suspension



**MINIMIKADO** 170  
Suspension



**NEW WAVE** 176  
Suspension



**NUT** 180  
Suspension



**BLACK NOTE** 70  
Keys / Suspension,  
Floor & Wall



**BLACK NOTE** 70  
Triplet / Suspension,  
Floor & Wall



**CANDELABRO** 84  
Suspension



**CARAMBOLA** 90  
Suspension



**OH!LINE** 38  
Suspension



**POD & POPPY** 192  
Suspension



**RAINDROP** 196  
Suspension



**SATURNIA** 192  
Suspension



**CUAD** 102  
Suspension



**DANDELION** 106  
Suspension



**DOMO** 110  
Suspension



**DUNE** 16  
Suspension



**SPIRO** 204  
Suspension



**STITCHES** 210  
Suspension



**SUNS** 50  
Suspension Panel



**SWIRL** 214  
Suspension



**ESCAPE** 114  
Suspension



**ERIS** 24  
Suspension & Table

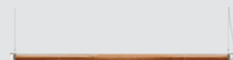

**ESTELA** 20  
Suspension



**GEA** 118  
Susp., Floor, Wall &  
Ceiling



**TOMO** 30  
Suspension & Table



**TOTEM** 218  
Suspension



**X-CLUB** 230  
Suspension & Ceiling



**I-CLUB** 134  
Susp., Table, Wall  
& Ceiling



**I-LINE** 42  
Suspension



**LINK** 148  
Suspension & Floor



**LOLA** 156  
Suspension, Table & Floor



**BIG BIRD** 244  
Suspension



**WALKING FISH** 240  
Floor



**SMELLY FANT** 236  
Floor



**KOI & KOGOI** 252  
Suspension

## 2

### LIFE SIZE



# INDEX

## 3

**TABLE**



**AIR** 62  
Table & Wall



**CHOU** 98  
Table



**CHOU** 98  
Table

## 5

**CORDLESS**



**MINI CHOU** 94  
Table

## 6

**WALL & CEILING**



**AIR** 62  
Table & Wall



**ERIS** 24  
Suspension & Table



**I-CLUB** 134  
Susp., Table, Wall & Ceiling



**LOLA** 156  
Suspension, Table & Floor



**LOLA LUX** 156  
Table



**BLACK NOTE** 70  
Duplet / Suspension, Floor & Wall



**GEA** 118  
Susp., Floor, Wall & Ceiling



**LOLA** 156  
Suspension, Table, Floor & Wall



**GUIJARRO** 126  
Wall & Ceiling



**LENS** 142  
Table, Floor & Wall



**LENS** 142  
Table, Floor & Wall



**TOMO** 30  
Suspension & Table



**THESIS** 222  
Table, Floor & Wall



**GUIJARRO** 126  
Wall & Ceiling



**GUIJARRO** 126  
Wall & Ceiling



**HI-COLLAR** 130  
Wall



**I-CLUB** 134  
Suspension, Table, Wall & Ceiling

## 4

**FLOOR**



**BLACK NOTE** 70  
Triplet / Suspension, Floor & Wall



**COSMOS** 118  
Susp., Floor, Wall & Ceiling



**LENS** 142  
Table, Floor & Wall



**LENS** 34  
Table, Floor & Wall



**LENS** 34  
Table, Floor & Wall



**LENS** 34  
Table, Floor & Wall



**PLEG** 188  
Wall



**LENS** 142  
Table, Floor & Wall



**LINK** 148  
Suspension & Floor



**LOLA** 156  
Suspension, Table & Floor



**THESIS** 222  
Table, Floor & Wall



**ORBIT** 184  
Wall

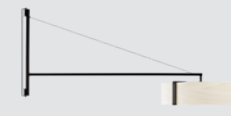

**THESIS** 222  
Table, Floor & Wall



**X-CLUB** 230  
Suspension & Ceiling



LATEST  
COLLEC  
TION



# DUNE

## Dune

Designed by:  
Mayice Studio

Dune is a sculptural light whose shape is intriguingly amorphous. Designed by Madrid-based Mayice Studio, Dune is a single piece of hand-blown borosilicate glass, enveloping a wood veneer diffuser with a seedpod-like opening on one side. The glass is hand-blown by Eduard Garuti, an accomplished artisan. With mastery and great dexterity, the work of Mayice and Garuti is able to reveal the natural beauty found in glass and combine this to perfection with the wood.

Dune's distinctive shape is made up of two symmetrical ends, and an irregular, bulb-shaped centre. The wood veneer diffuser houses the lamp's dimmable LED light source, and downward light from the seedpod-like opening is softened by the glass. Each numbered Dune lamp is unique: the beauty found in the imperfection of hand-blown glass, with its almost wabi-sabi quality, ensures Dune is like a piece of art.



● **DUNE - SUSPENSION**

30 Turquoise & Glass. "Refugio en la Viña". Valencia, Spain. Architect: Ramón Esteve Estudio.

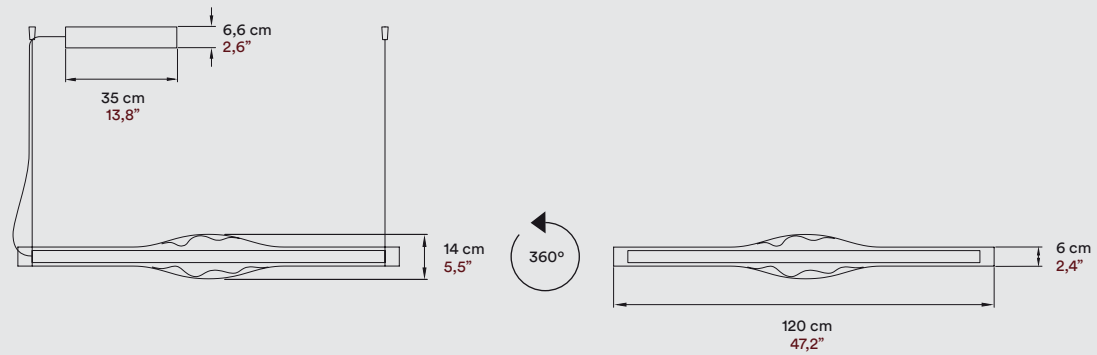

## MATERIALS & COMPONENTS

Wood Veneer Shade

Hand Blown Glass: Borosilicate

Metal Canopy

Coaxial Cable

2,5 m drop 8 ft drop

2 Steel Cables

2,5 m drop 8 ft drop

## LIGHT SOURCE

120 - 277V

LED Integrated  
Dimmable 0-10V, Bluetooth or DALI

Class I

120 - 277V

LED Integrated  
Dimmable 0-10V or TRIAC

US

## FINISHES

### WOOD VENEER

- |  |                   |  |              |
|--|-------------------|--|--------------|
|  | 20 Ivory White    |  | 30 Turquoise |
|  | 21 Natural Cherry |  | 33 Pale Rose |
|  | 22 Natural Beech  |  | 34 Sea Blue  |

## AWARDS



USA



USA

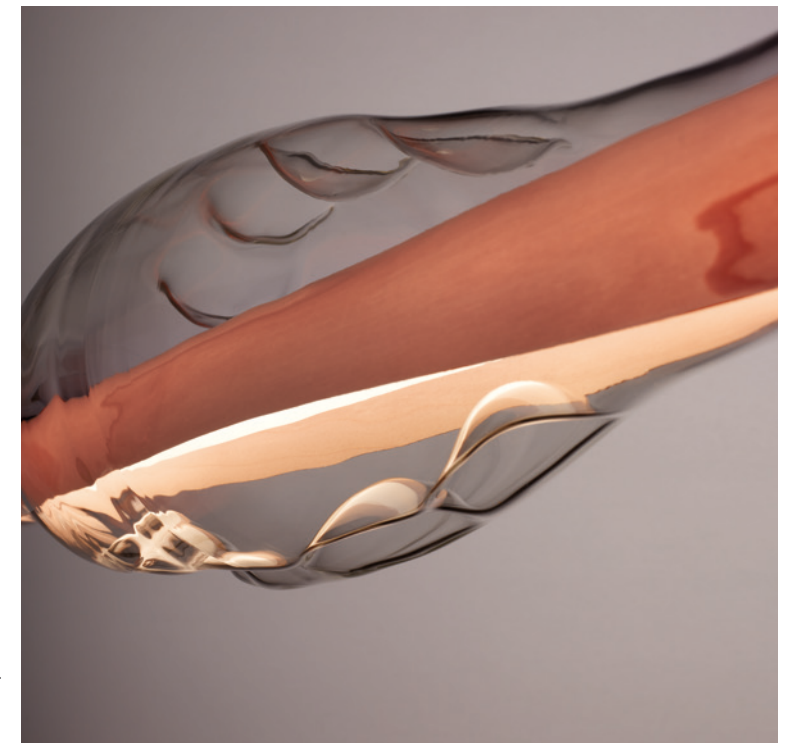

- **DUNE - SUSPENSION**  
21 Natural Cherry Wood Veneer & Glass.
- **DUNE - SUSPENSION**  
33 Pale Rose Wood Veneer & Glass.



# ESTELA

Designed by:  
Mayice Studio

## Estela

Estela is a captivating capsule of light. In Estela, Mayice Studio designed a clean, clear, single piece of borosilicate glass. Hand-blown by the accomplished artisan Eduard Garuti, the glass envelopes a cylinder-like wood veneer diffuser. The wood veneer houses a dimmable LED light source, and a straight opening on one side emits downward light that is softened by the glass.

Offering a seamless connection between both glass and wood, Estela is a radiant lamp with a celestial-like quality. It can also be used together with Dune to create alternating design solutions for board rooms, offices, and hospitality settings. Estela's natural imperfections, a characteristic of hand-blown glass, add to its warmth and elegance.

● **ESTELA - SUSPENSION**  
20 Ivory White Wood Veneer & Glass.





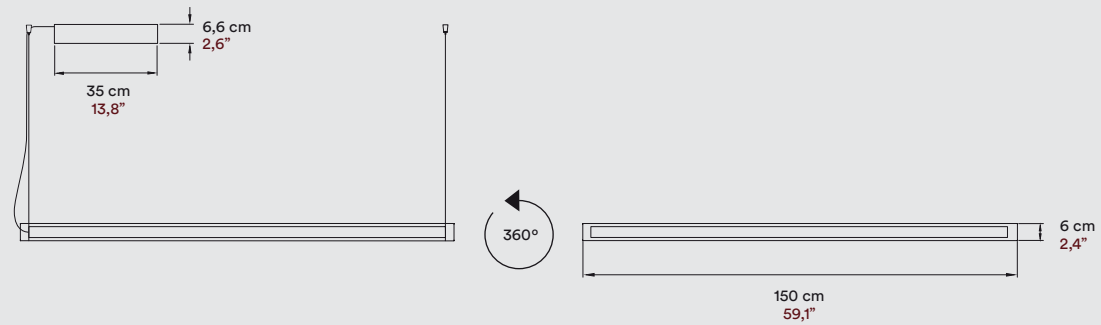

## MATERIALS & COMPONENTS

Wood Veneer Shade

Hand Blown Glass: Borosilicate

Metal Canopy

Coaxial Cable

2,5 m drop 8 ft drop

2 Steel Cables

2,5 m drop 8 ft drop

## LIGHT SOURCE

120 - 277V

LED Integrated

Dimmable 0-10V, Bluetooth or DALI

Class I 

120 - 277V



LED Integrated

Dimmable 0-10V or TRIAC

 US

## FINISHES

### WOOD VENEER

- |   |                   |   |              |
|---|-------------------|---|--------------|
|  | 20 Ivory White    |  | 33 Pale Rose |
|  | 21 Natural Cherry |  | 34 Sea Blue  |
|  | 22 Natural Beech  |   |              |



• ESTELA - SUSPENSION  
33 Pale Rose Wood Veneer & Glass.

\*Second image: View from below,  
reflected on the glass table.



## Eris

Suspension  
Table

Designed by:  
Mayice Studio

Eris has an abstract and ethereal beauty, similar to the planet of the same name. Designed by Mayice Studio, Eris is made up of several components: an original borosilicate glass orb, hand-blown by Master Artisan glass-blower Eduardo Garuti, a wood veneer tube (that contains the LED light source), and a metallic base.

Available as both a table lamp and a suspension lamp, Eris is sublime. Radiant when the light is on and ornamental when off, Eris has an ethereality that captures the perfect symbiosis of Glass and wood.

- **ERIS - TABLE**  
22 Natural Beech Wood Veneer, Glass & Metal Structure.

# ERIS

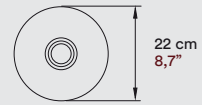
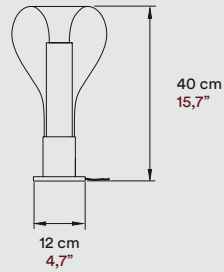

## MATERIALS & COMPONENTS

Wood Veneer Shade

Hand Blown Glass: Borosilicate

Metal Base

Electrical Cable with Dimming Switch  
145 cm 57"

## LIGHT SOURCE

220 - 250V  
Bulb GU10





Class II  

120V  
Bulb GU10





## FINISHES

### WOOD VENEER

- |   |  |
|---|--|
|  20 Ivory White    |  22 Natural Beech |
|  21 Natural Cherry |  33 Pale Rose     |

### ESTRUCTURE

- |  |   |
|--|---|
|  AL-Aluminium |  BK-Matt Black |
|--|---|



● ERIS - TABLE  
22 Natural Beech Wood Veneer, Glass & Metal Structure.



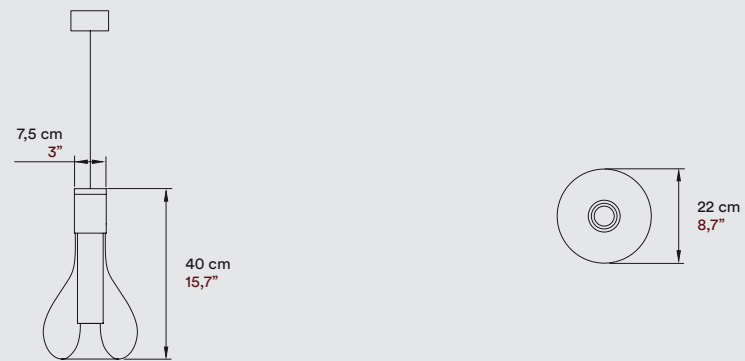

## MATERIALS & COMPONENTS

Wood Veneer Shade

Hand Blown Glass: Borosilicate

Metal Structure

Metal Canopy

Electrical Cable  
2,5 m drop 8 ft drop

## LIGHT SOURCE

220 - 250V  
Bulb GU10

Class I

120V  
Bulb GU10

## FINISHES

### WOOD VENEER

- 20 Ivory White
- 22 Natural Beech
- 21 Natural Cherry
- 33 Pale Rose

### ESTRUCTURE

- AL-Aluminium
- BK-Matt Black



### • ERIS - SUSPENSION

20 Ivory White Wood Veneer, Glass & Metal Structure.  
"Refugio en la Viña". Valencia, Spain. Architect: Ramón Esteve Estudio.

Tomo

T O

Designed by:  
MUT Design

Suspension  
Table

Tomo is a lamp whose design is reminiscent of books placed side by side. This thoughtful and earnest lamp was designed by Valencia-based Mut Design Studio.

Tomo is presented as a chain of wood veneer oblongs, with varying heights and widths. The

resulting shapes are both graphic and geometric in form. Tomo is designed as a table lamp and a suspension lamp, with dimmable LED, and a light-filtering diffuser. As a table lamp, Tomo's arrangement is evocative of book spines; as a pendant, Tomo appears like an illuminated row of hanging volumes.



M O

• TOMO - SUSPENSION | 22 Natural Beech, 34 Sea Blue & 20 Ivory White Wood Veneer

• TOMO - TABLE

20 Ivory White Wood Veneer.

"Goded" Housing, Valencia, Spain. Project: Raw Arquitectura. Photography: Cualiti Photo Studio. Furniture: Annud.



## TALL

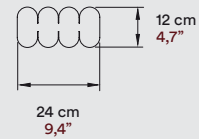
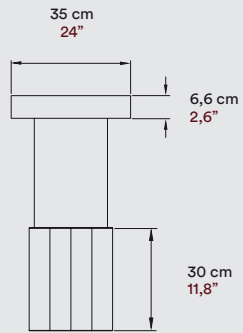

## LONG

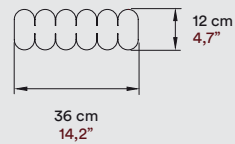
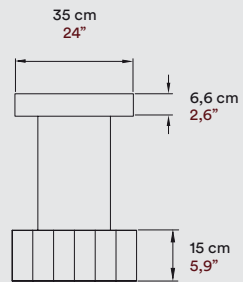

## MATERIALS &amp; COMPONENTS

Wood Veneer Shade

Bottom Acrylic Diffuser

Metal Structure







Metal Canopy

2 Electrified Steel Cables

2,5 m drop 8 ft drop

## FINISHES

WOOD VENEER

- |   |                   |   |              |
|---|-------------------|---|--------------|
|  | 20 Ivory White    |  | 24 Yellow    |
|  | 21 Natural Cherry |  | 33 Pale Rose |
|  | 22 Natural Beech  |  | 34 Sea Blue  |

## LIGHT SOURCE

120 - 277V

LED Integrated

Dimmable 0-10V or Bluetooth

Class I 

120 - 277V

LED Integrated

Dimmable 0-10V &amp; TRIAC

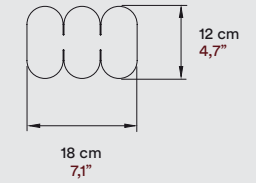
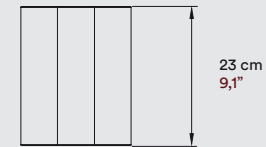
 PENDING

## MATERIALS &amp; COMPONENTS

Wood Veneer Shade

Upper Acrylic Diffuser

Metal Base







Electrical Cable with Dimming Switch

145 cm 57"

Plug-in Driver

## FINISHES

WOOD VENEER

- |   |                   |   |              |
|---|-------------------|---|--------------|
|  | 20 Ivory White    |  | 24 Yellow    |
|  | 21 Natural Cherry |  | 33 Pale Rose |
|  | 22 Natural Beech  |  | 34 Sea Blue  |

## LIGHT SOURCE

LED Integrated Dimmable

LED Integrated Dimmable

Class II  PENDING

# LENS

## Lens

Wall  
Floor  
Table

Designed by:  
Mut Design



• LENS  
20 Ivory White Wood Veneer, Gold Metal Structure & Mirror.

The new wall version of LZF's Lens lamp incorporates an eye-catching central mirror. Designed by Mut Design Studio, Lens is a lamp created with flowing lines and no hard edges. The Lens wall lamp is available in three shapes: circle, oval, and super oval.

Made up of wood veneer, a metal ring and back plate, the new mirror fitting is an alluring addition to the Lens wall lamp. The lamp's dimmable LED provides a soft, halo-like warmth. A light that works as a single fixture or in a group, the Lens wall lamp adds a reflective depth to any space.



• LENS - WALL OVAL  
20 Ivory White Wood Veneer, Gold Metal Structure & Mirror.  
"Casa en la Huerta". Valencia, Spain. Architect: Ramón Esteve Estudio.

**LENS** **WALL** **MUT DESIGN**

**CIRCULAR**

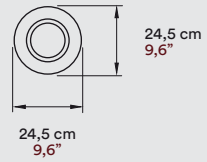

**OVAL**

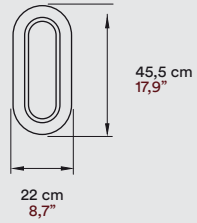

**SUPEROVAL**

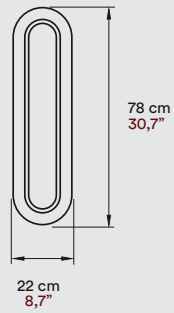

**MATERIALS & COMPONENTS**

Wood Veneer Shade

Central Mirror

Metal Ring

**LIGHT SOURCE**

**120-277V**  
LED Integrated  
Dimmable 0-10V

Class I

**120 - 277V**  
LED Integrated  
Dimmable 0-10V & TRIAC



**ADA Compliant**

**FINISHES**

**WOOD VENEER**

- 20 Ivory White
- 28 Blue
- 21 Natural Cherry
- 29 Grey
- 22 Natural Beech
- 33 Pale Rose

**METAL**

- IV-Matt Ivory
- NI-Matt Nickel
- BK-Matt Black
- GD-Gold



● **LENS - WALL CIRCULAR**  
20 Ivory White Wood Veneer, Gold Metal & Mirror. Photo: 4000k.  
"Casa en la Huerta". Valencia, Spain. Architect: Ramón Esteve Estudio.





## Oh!Line

Medium  
Large

Designed by:  
Burkhard Dämmer  
& Mariví Calvo

Imagine sitting beneath a halo of light. This is the effect created by Oh!Line, a svelte circle of light. Designed by Mariví Calvo & Burkhard Dämmer, Oh!Line is available in two sizes: medium and large suspension.

With its slim form, wood veneer, dimmable LED, and light-filtering diffuser, Oh!Line radiates warmth and elegance. Light from the ring-shaped Oh!Line provides a relaxed ambience and a focused glow

- OH!LINE - SUSPENSION  
20 Ivory White Wood Veneer.



## MEDIUM

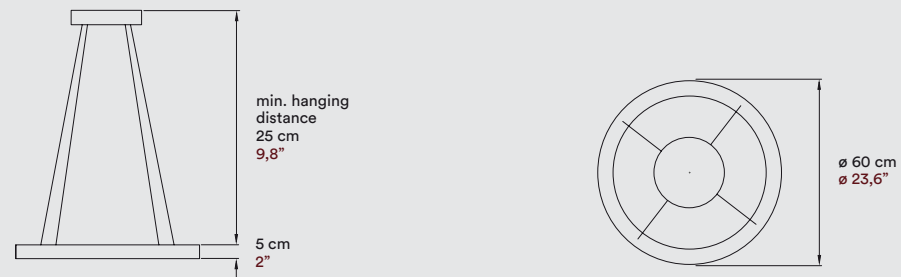

## LARGE



## MATERIALS &amp; COMPONENTS

## Wood Veneer Shade

## Bottom Acrylic Diffuser

## Metal Canopy

## 2 Steel Cables

2,5 m drop 8 ft drop

## 2 Electrified Cables

2,5 m drop 8 ft drop

## LIGHT SOURCE

## 120 - 277V

LED Integrated  
Dimmable 0-10V, Bluetooth or DALI

Class I

## 120 - 277V

LED Integrated  
Dimmable 0-10V & TRIAC

## FINISHES

## WOOD VENEER

	20 Ivory White		26 Red
	21 Natural Cherry		28 Blue
	22 Natural Beech		29 Grey
	24 Yellow		33 Pale Rose
	25 Orange		34 Sea Blue

## METAL CANOPY

	BK-Matt Black		NI-Matt Nickel
	WH-Matt White		



## ● OH|LINE - SUSPENSION

20 Ivory White Wood Veneer.

"Refugio en la Viña". Valencia, Spain. Architect: Ramón Esteve Estudio.



# I-Line

Short  
Long

Designed by:  
Burkhard Dämmer

I-LINE

I-Line is a smooth and sleek lamp, with a clean, architectural line. Designed by long-time LZF collaborator Burkhard Dämmer, I-Line is available in two sizes: medium and large suspension.

I-Line's unfussy design is perfect in places and spaces that call for a practical, yet elegant,

luminaire: above a countertop or a work table, for example. I-Line's wood veneer, dimmable LED, and light-filtering diffuser, provide both direct and ambient light. In I-Line, Burkhard Dämmer has created a lamp that is simple, symmetrical and serene.

● **I-LINE - SUSPENSION**

20 Ivory White Wood Veneer.

"Refugio en la Viña". Valencia, Spain. Architect: Ramón Esteve Estudio



## SHORT

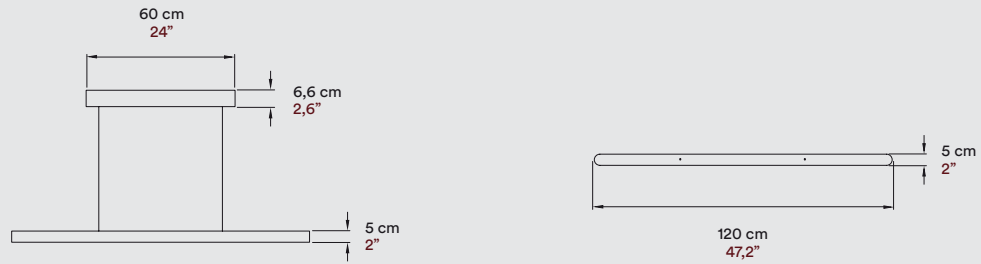

## LONG

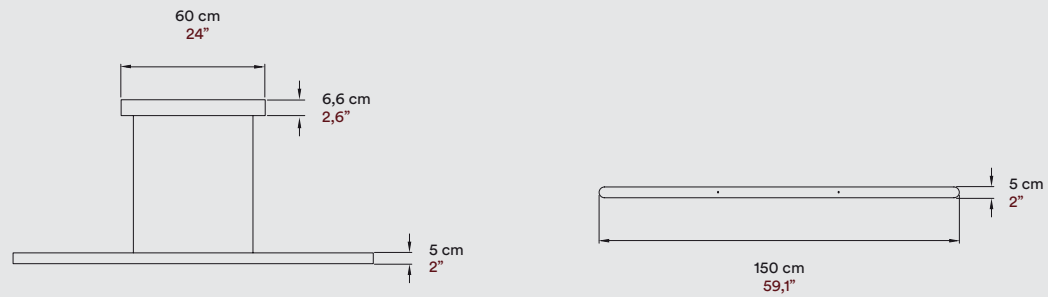

## MATERIALS &amp; COMPONENTS

Wood Veneer Shade

Bottom Acrylic Diffuser

Metal Canopy

2 Electrified Cables

2,5 m drop 8 ft drop

## LIGHT SOURCE

120 - 277V









LED Integrated  
Dimmable 0-10V, Bluetooth or DALIClass I 

120 - 277V



LED Integrated  
Dimmable 0-10V & TRIAC

## FINISHES

## WOOD VENEER

 20 Ivory White	 26 Red
 21 Natural Cherry	 28 Blue
 22 Natural Beech	 29 Grey
 24 Yellow	 33 Pale Rose
 25 Orange	 34 Sea Blue

## METAL CANOPY

 BK-Matt Black	 NI-Matt Nickel
 WH-Matt White	



- I-LINE - SUSPENSION  
20 Ivory White Wood Veneer.



- I-LINE - SUSPENSION  
26 Red Wood Veneer.





# Maruja

Designed by:  
Gaspacho Studio

An original self-assembly pendant, Maruja was designed by the fresh-faced Gaspacho Studio—it is LZF's first flat-pack fixture. A contemporary lamp, Maruja's design is simultaneously unfussy and decorative. Maruja is a name whose origins lie in Galicia, and signifies both femininity and strength.

The do-it-yourself Maruja is packaged with all the components needed to assemble the lamp: wood veneer strips (in several sizes), a circular frame, and pins. Maruja is easily constructed, without the need for any tools or adhesives. Using a pin, each wooden strip is clipped onto the circular frame—insert a light bulb, and you will have created an elegant, handmade lamp. The wood veneer strips hang and move freely, and when illuminated, Maruja sparkles with life.

- **MARUJA - SUSPENSION**  
33 Pale Rose Wood Veneer.



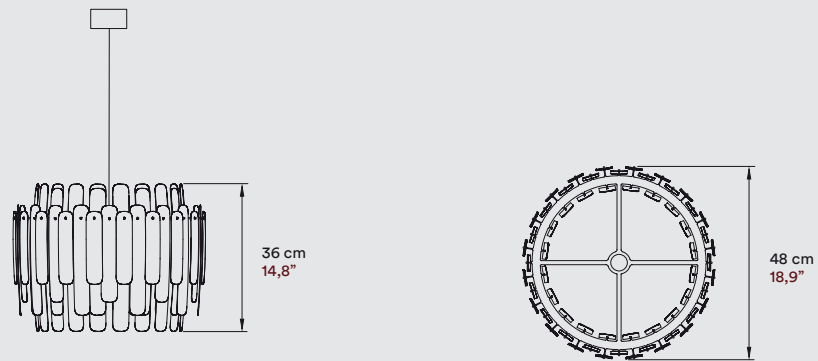

**MATERIALS & COMPONENTS**

Wood Veneer Shade

Metal Tripod

Metal Canopy

Electrical Cable  
2,5 m drop 8 ft drop

**LIGHT SOURCE**

220 - 250V  
Bulb E27

Class I

120 - 277V  
Bulb E26

**FINISHES**

**WOOD VENEER**

- |                   |              |
|-------------------|--------------|
| 20 Ivory White    | 26 Red       |
| 21 Natural Cherry | 28 Blue      |
| 22 Natural Beech  | 29 Grey      |
| 24 Yellow         | 33 Pale Rose |
| 25 Orange         | 34 Sea Blue  |

**METAL CANOPY**

- |               |                |
|---------------|----------------|
| BK-Matt Black | NI-Matt Nickel |
| WH-Matt White |                |



• MARUJA - SUSPENSION  
22 Natural Beech Wood Veneer.



# SUNS

## Suns

Designed by:  
Mikiya Kobayashi

Small  
Medium  
Large

Suns is a celestial-like decorative panel that acts to diffuse light and break sound. Designed by Tokyo & Valencia-based Mikiya Kobayashi, Suns is available in three sizes: small, medium, and large.

Japan is affectionately known as the 'land of the rising sun', and in Suns we find a handmade,

circular wood panel that is characterised by a quiet and respectful beauty-an inherent Japanese quality. Without light or electrification, the Suns panel is made up of wood veneer and a metal canopy. Designed to hang at an angle, Suns is striking and stellar when placed in a cluster formation.



● SUNS - DECORATIVE PANEL  
20 Ivory White Wood Veneer.  
"Kaido" Japanese Restaurant, Valencia, Spain.



## SMALL

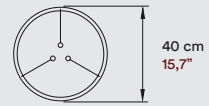

## MEDIUM

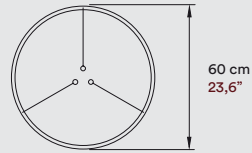

## LARGE

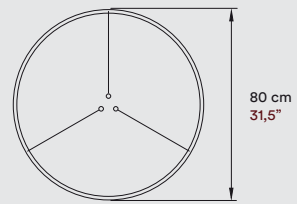
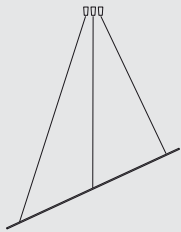

## MATERIALS &amp; COMPONENTS

Wood Veneer Panel

Metal Structure

3 Steel Cables  
2,5 m drop 8 ft drop

**THIS FIXTURE IS NOT ELECTRIFIED AND  
CONTAINS NO LIGHT SOURCE**

“Suns are innovative decorative circular panels that can be installed at different angles and that break up sound and interact with light. Do not contain light source”.

## FINISHES

WOOD VENEER

● 20 Ivory White



- **SUNS - DECORATIVE PANEL**  
20 Ivory White Wood Veneer.  
“Refugio en la Viña”. Valencia, Spain.  
Architect: Ramón Esteve Estudio.





# THE COLLEC TION



A

G A

# Agatha

Designed by:  
Luis Eslava Studio

Ball  
Small  
Large

With an arresting and dramatic demeanour, Agatha fills the room with her ambient glow and appealing body. Agatha's elegant interlacing whorls of handmade wood veneer strips spring concentrically from its centre, their mass blossoming and flourishing.



● **AGATHA - SMALL SUSPENSION**  
20 Ivory White Wood Veneer. "Alameda" Restaurant. Madrid, Spain.  
Architect: José Castro. Interior Designer: Evangelía Chalastsakos.

## BALL

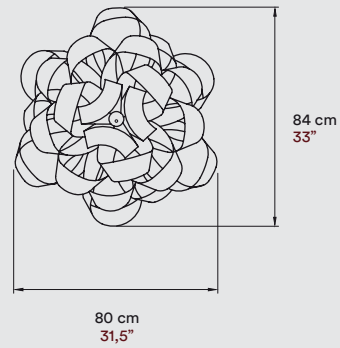
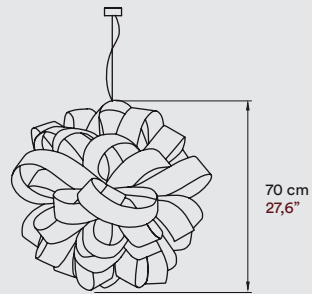

## MATERIALS &amp; COMPONENTS

## Wood Veneer Shade

## Metal Canopy

## Steel Cable

2,5 m drop 8 ft drop

## Electrical Cable

2,5 m drop 8 ft drop

## FINISHES

## WOOD VENEER

- 20 Ivory White
- 25 Orange
- 22 Natural Beech
- 33 Pale Rose
- 24 Yellow

## LIGHT SOURCE

## 120 - 277V

LED Integrated  
Dimmable 0-10V, Bluetooth or DALI  
or

## 220 - 250V

6 Bulbs E27

Class I 

## AWARDS

HD Las Vegas. Product Design Competition. USA

WAN LIGHTING. World Architecture Award. USA

## 120 - 277V

LED Integrated  
Dimmable 0-10V & TRIAC  
or

## 120 - 277V

6 Bulbs E26



- **AGATHA - SMALL SUSPENSION**  
20 Ivory White Wood Veneer.

- **AGATHA - BALL SUSPENSION**  
20 Ivory White Wood Veneer.  
"Palau de Casavells". Girona, Spain.

- **AGATHA - LARGE SUSPENSION**  
20 Ivory White Wood Veneer.  
"Villa El Nido". Architects: A-cero. Marbella, Spain.

## SMALL

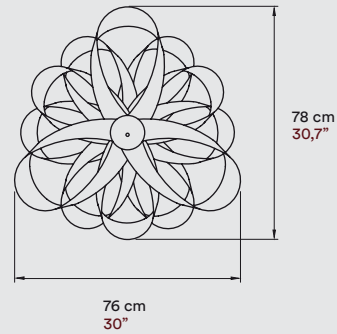
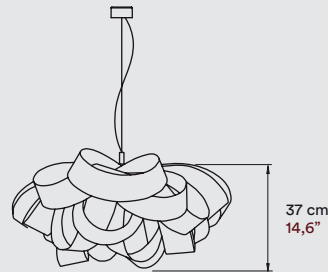

## MATERIALS &amp; COMPONENTS

## Wood Veneer Shade

## Metal Canopy

## Steel Cable

2,5 m drop 8 ft drop

## Electrical Cable

2,5 m drop 8 ft drop

## LIGHT SOURCE

## 120 - 277V

LED Integrated  
Dimmable 0-10V, Bluetooth or DALI  
or

## 220 - 250V

Bulb E27

Class I

## 120 - 277V

LED Integrated  
Dimmable 0-10V & TRIAC  
or

## 120 - 277V

Bulb E26



## FINISHES

## WOOD VENEER

20 Ivory White	26 Red
21 Natural Cherry	28 Blue
22 Natural Beech	29 Grey
24 Yellow	33 Pale Rose
25 Orange	34 Sea Blue

## LARGE

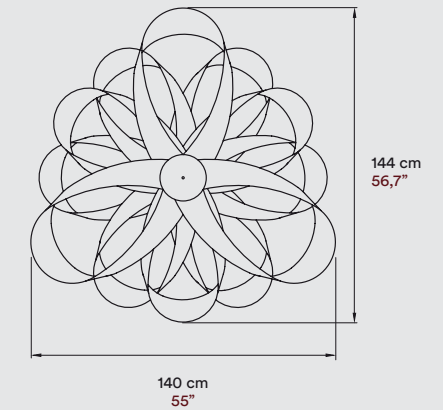
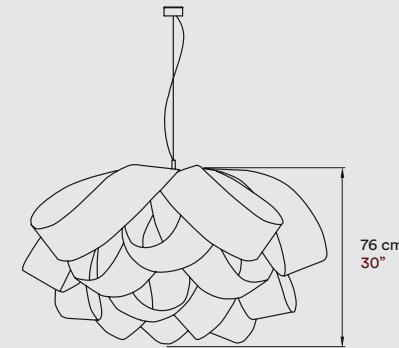

## MATERIALS &amp; COMPONENTS

## Wood Veneer Shade

## Metal Canopy

## Steel Cable

2,5 m drop 8 ft drop

## Electrical Cable

2,5 m drop 8 ft drop

## LIGHT SOURCE

## 120 - 277V

LED Integrated  
Dimmable 0-10V, Bluetooth or DALI  
or

## 220 - 250V

3 Bulbs E27

Class I

## 120 - 277V

LED Integrated  
Dimmable 0-10V & TRIAC  
or

## 120 - 277V

3 Bulbs E26



## FINISHES

## WOOD VENEER

20 Ivory White	26 Red
21 Natural Cherry	28 Blue
22 Natural Beech	29 Grey
24 Yellow	33 Pale Rose
25 Orange	34 Sea Blue



# AIR



## Air

Table  
Wall

Designed by:  
Ray Power

The Air light is sublime, graceful and enchanting. Its shape exhibits the designer's characteristic penchant for imaginative three-dimensional forms. The Air lamp's pleats and folds work to create a unique wood veneer light, one whose character demonstrates balance with equanimity and restraint.

Air lamp diffuses light in a manner that is flawless and low-key, its singular silhouette shining with a radiant warmth and vitality. A free-flowing, effortless light, Air lamp enjoys a distinctly individual profile.

• **AIR - WALL**  
20 Ivory White Wood Veneer. "Caro" Hotel. Valencia, Spain.



• **AIR - TABLE**  
24 Yellow Wood Veneer. "Villa El Nido". Architects: A-cero. Marbella, Spain.

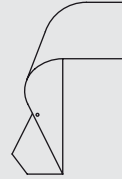
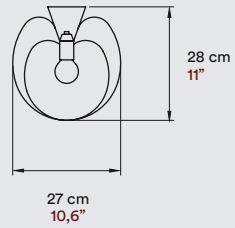
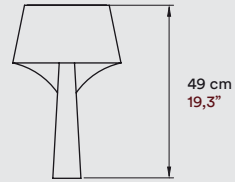

## MATERIALS & COMPONENTS

Wood Veneer Shade

Metal Base

Electrical Cable with Dimming Switch  
145 cm 57"

## LIGHT SOURCE

220 - 250V  
Bulb E14

Class II

120V  
Bulb E12



## FINISHES

WOOD VENEER

- |                   |              |
|-------------------|--------------|
| 20 Ivory White    | 26 Red       |
| 21 Natural Cherry | 28 Blue      |
| 22 Natural Beech  | 29 Grey      |
| 24 Yellow         | 33 Pale Rose |
| 25 Orange         | 34 Sea Blue  |

## AWARDS



Chicago

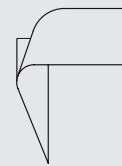
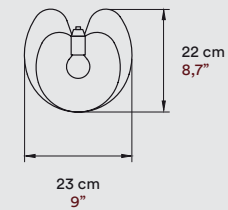
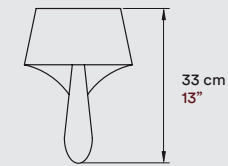

## MATERIALS & COMPONENTS

Wood Veneer Shade

Metal Back Plate

## LIGHT SOURCE

220 - 250V  
Bulb E14

Class I

120V  
Bulb E12



## FINISHES

WOOD VENEER

- |                   |              |
|-------------------|--------------|
| 20 Ivory White    | 26 Red       |
| 21 Natural Cherry | 28 Blue      |
| 22 Natural Beech  | 29 Grey      |
| 24 Yellow         | 33 Pale Rose |
| 25 Orange         | 34 Sea Blue  |

# BANGA

## Banga

Designed by:  
Yonoh Creative Studio

Medium  
Large

The Banga light's combined veneer pieces and metal frame bear a resemblance to a plush brolly or indeed, to a well dressed parasol. Banga enjoys an expressive Eastern world-like quality, together with a nod to neoclassicism and its principles of simplicity and symmetry.

- **BANGA - LARGE SUSPENSION**  
26 Red Wood Veneer. "Le Meridien" Hotel. Tarragona, Spain.





**BANGA**

**SUSPENSION**

**YONOH CREATIVE STUDIO**

**MEDIUM**

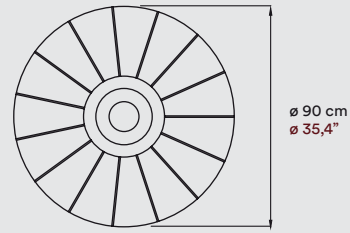
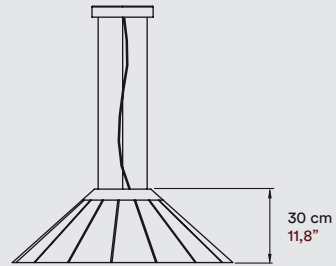

**LARGE**

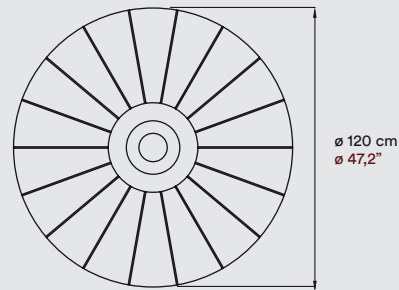
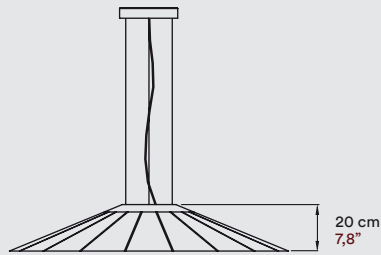

**MATERIALS & COMPONENTS**

Wood Veneer Shade

Acrylic Diffuser

Metal Structure & Canopy

3 Steel Cables  
2,5 m drop 8 ft drop

Electrical Cable  
2,5 m drop 8 ft drop

**LIGHT SOURCE**

**120 - 277V**  
LED Integrated  
Dimmable 0-10V, Bluetooth or DALI

Class I CE

**120 - 277V**  
LED Integrated  
Dimmable 0-10V & TRIAC



Chicago



Germany

**FINISHES**

**WOOD VENEER**

- 20 Ivory White
- 26 Red
- 21 Natural Cherry
- 28 Blue
- 22 Natural Beech
- 29 Grey
- 24 Yellow
- 33 Pale Rose
- 25 Orange
- 34 Sea Blue

**AWARDS**



• **BANGA - LARGE & MEDIUM SUSPENSION**  
33 Pale Rose, 24 Yellow & 29 Grey Wood Veneer.  
"Le Meridien" Hotel. Tarragona, Spain.

# B L A C K N O T E

Designed by:  
Ramón Esteve Estudio

## Black Note

Keys  
Triplet  
Duplet

Suspension  
Susp. & Floor  
Wall

Designed by Ramón Esteve, Black Note is a lamp with perpendicular shades that rise and fall in harmony. Its rhythmic arrangement is inspired by the black keys on a piano, whose sharp and flat notes add emotion and passion to a melody.

Black note's metal frame in our new metallic finishes work, works harmoniously with its luminous, warm wood veneer shades. Ramón Esteve created three Black Note compositions: Black Note Keys (horizontal), Black Note Triplets (suspension & floor) and Black Note Duplets (wall). These differing compositions, with their rhythmic forms, offer a symphony of light, texture and pattern.

### • BLACK NOTE KEYS - SUSPENSION

20 Ivory White Wood Veneer & Matt Black Metal Structure & Canopy.  
"Casa en la Huerta". Valencia, Spain. Architect: Ramón Esteve Estudio.







---

● **BLACK NOTE KEYS - SUSPENSION**

22 Natural Beech Wood Veneer & Gold Metal Structure & Canopy.

---

The Black Note Keys has dual electrical circuits. Both circuits can be dimmed independently of one another making an almost infinite combination of light blends possible.



## KEYS

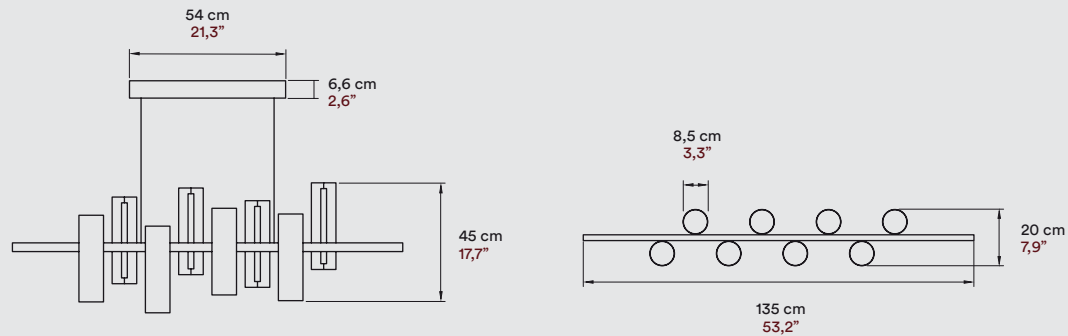

## MATERIALS &amp; COMPONENTS

## 8 Wood Veneer Shades

## Metal Structure &amp; Canopy

## 4 Electrified Steel Cables

2,5 m drop 8 ft drop

## LIGHT SOURCE

**Dual Circuit - DC.** Enables independent dimming and control of the decorative wood shades and the tech downlight.

**120 - 277V**

LED Integrated

Dimmable 0-10V, Bluetooth or DALI

Class I **120 - 277V**

LED Integrated

Dimmable 0-10V &amp; TRIAC







## FINISHES

## WOOD VENEER

- |   |                   |   |                  |
|---|-------------------|---|------------------|
|  | 20 Ivory White    |  | 22 Natural Beech |
|  | 21 Natural Cherry |  | 29 Grey          |

## METAL

- |   |               |   |                |
|---|---------------|---|----------------|
|  | IV-Matt Ivory |  | NI-Matt Nickel |
|  | BK-Matt Black |  | GD-Gold        |



## ● BLACK NOTE KEYS - SUSPENSION

21 Natural Cherry Wood Veneer &amp; Matt Black Metal Structure &amp; Canopy.

## TRIPLET

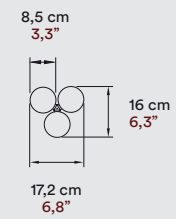
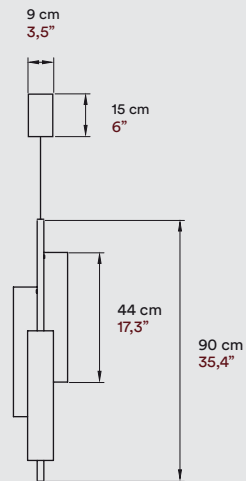

## MATERIALS &amp; COMPONENTS

## 3 Wood Veneer Shades

## Metal Structure &amp; Canopy

## Electrical Cable

2,5 m drop 8 ft drop

## LIGHT SOURCE

## 120 - 277V

LED Integrated  
Dimmable 0-10V, Bluetooth or DALI

Class I

## 120 - 277V

LED Integrated  
Dimmable 0-10V & TRIAC

## FINISHES

## WOOD VENEER

- |  |                   |  |                  |
|--|-------------------|--|------------------|
|  | 20 Ivory White    |  | 22 Natural Beech |
|  | 21 Natural Cherry |  | 29 Grey          |

## METAL

- |  |               |  |                |
|--|---------------|--|----------------|
|  | IV-Matt Ivory |  | NI-Matt Nickel |
|  | BK-Matt Black |  | GD-Gold        |



## • BLACK NOTE TRIPLET - SUSPENSION

20 Ivory White Wood Veneer &amp; Gold Metal Structure &amp; Canopy.





---

● **BLACK NOTE TRIPLET - SUSPENSION**  
20 Ivory White & 21 Natural Cherry Wood Veneer with Ivory White & Matt Black Metal Structure.

---

● **BLACK NOTE TRIPLET - SUSPENSION**  
22 Natural Beech & 29 Grey Wood Veneer with Gold & Matt Black Metal Structure.

## TRIPLET

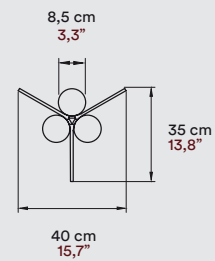
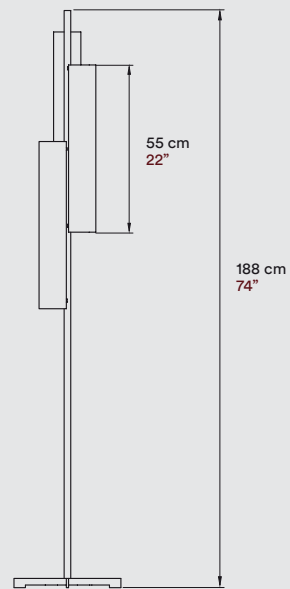

## MATERIALS &amp; COMPONENTS

## 3 Wood Veneer Shades

## Metal Stem &amp; Base

## Electrical Cable with Dimming Switch

185 cm 73"

## LIGHT SOURCE

230V  
LED Integrated Dimmable

Class II  

120V  
LED Integrated Dimmable



## FINISHES

## WOOD VENEER

- |   |                   |   |                  |
|---|-------------------|---|------------------|
|  | 20 Ivory White    |  | 22 Natural Beech |
|  | 21 Natural Cherry |  | 29 Grey          |

## METAL

- |   |               |   |                |
|---|---------------|---|----------------|
|  | IV-Matt Ivory |  | NI-Matt Nickel |
|  | BK-Matt Black |  | GD-Gold        |



## ● BLACK NOTE TRIPLET - FLOOR

20 Ivory White Wood Veneer & Matt Black Metal Base.  
"Casa en la Huerta". Valencia, Spain. Architect: Ramón Esteve Estudio.



## DUPLET

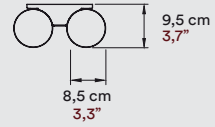
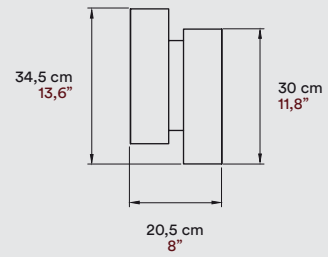

## MATERIALS &amp; COMPONENTS

2 Wood Veneer Shades

Metal Back Plate

## LIGHT SOURCE

120 - 277V  
LED Integrated  
Dimmable 0-10V

Class I 

120 - 277V  
LED Integrated  
Dimmable 0-10V & TRIAC







ADA Compliant

## FINISHES

## WOOD VENEER

- |   |  |
|---|--|
|  20 Ivory White    |  22 Natural Beech |
|  21 Natural Cherry |  29 Grey          |

## METAL

- |   |  |
|---|--|
|  IV-Matt Ivory |  NI-Matt Nickel |
|  BK-Matt Black |  GD-Gold        |



## ● BLACK NOTE DUPLET - WALL

29 Grey Wood Veneer & Matt Black Metal Back Plate. Photo: 4000k.  
"Casa en la Huerta". Valencia, Spain. Architect: Ramón Esteve Estudio.

# CAVI DE LABRO

## Candelabro

Small  
Large

Designed by:  
Mariví Calvo

Imagine a suspension light that embodies many of LZFF's greatest hits. Candelabro describes a remarkably representational form that unites the finest collection of wood veneer pendants. The performers include such luminaries as Agatha and Mikado, Raindrop and Totem. Hovering amid the lights are a number of golden birds, each one enjoying a magical world of wonder. Together, these birds and the various pendants stage a thrilling opus in light, a majestic piece that will give the viewer pleasure every time.

• CANDELABRO - SMALL SUSPENSION  
20 Ivory White Wood Veneer. "Alameda" Restaurant. Madrid, Spain.





## SMALL

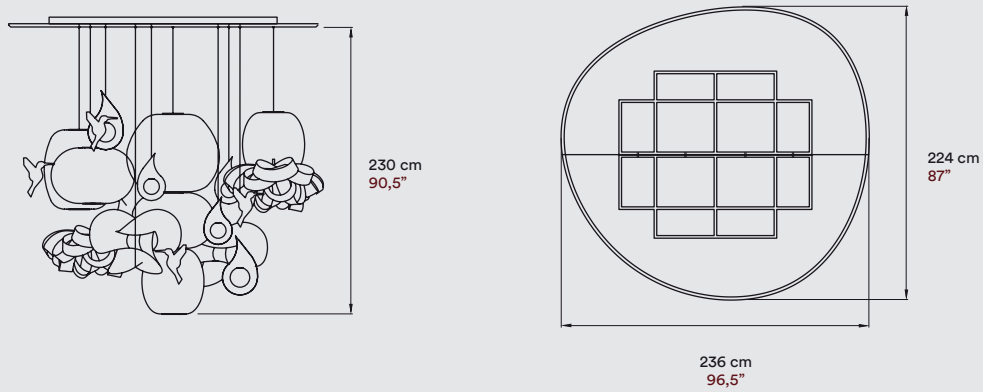

## LARGE

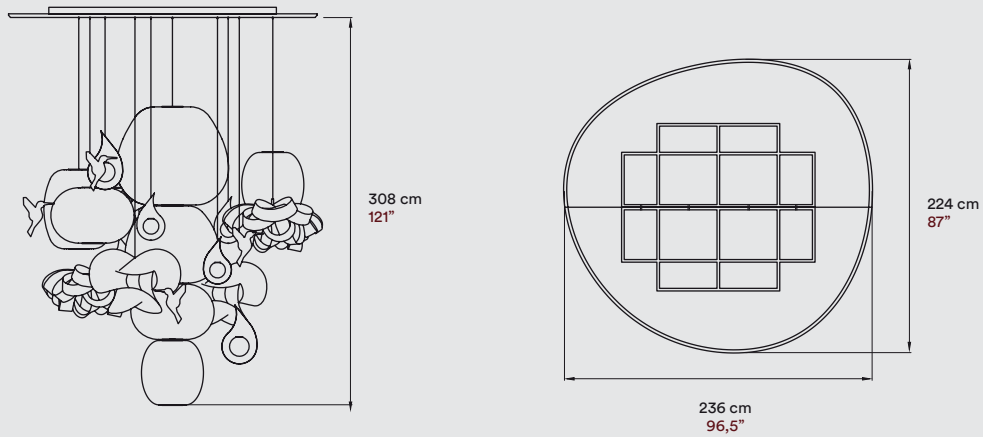

## MATERIALS &amp; COMPONENTS

15 Wood Veneer Shades

Lacquered Wood Canopy

Ceramic Birds in Gold or White Glaze

## FINISHES

## WOOD VENEER

● 20 Ivory White ● 22 Natural Beech

## LIGHT SOURCE

3 Independent Dimmable Circuits.  
Dimming & Control of the Central Shade,  
Periferal Shades & Soptlights.

220 - 250V

Class I CE

120V



● CANDELABRO  
LARGE SUSPENSION  
20 Ivory White Wood Veneer.  
LZF Showroom. Chiva, Valencia.





● CANDELABRO CUSTOM SUSPENSION

21 Natural Cherry Wood Veneer. GF Gran Costa Adeje Hotel\*\*\*\*\*, Tenerife, Spain. Project: Mayte Calzadilla (Architect GRUPO FEDOLA). Tech. Dep.: KAUXEX.

Photography: Richard Goncalves.



# Carambola

Small  
Medium

Designed by:  
Oskar Cerezo



AMC  
MRA  
OLA  
A



## SMALL

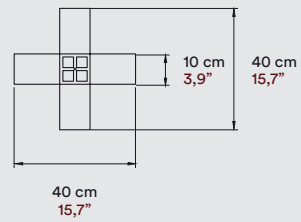
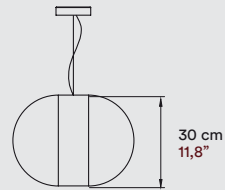

## MEDIUM

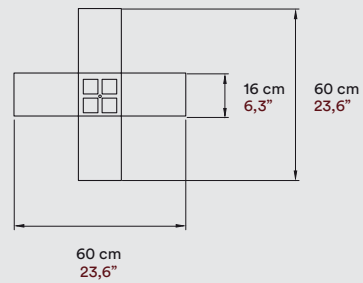
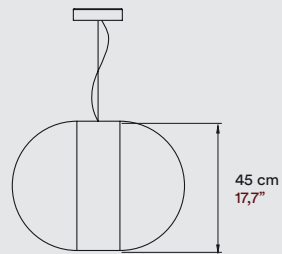

## MATERIALS &amp; COMPONENTS

Wood Veneer Shade

Acrylic Diffuser

Metal Trims &amp; Canopy

Steel Cable











2,5 m drop 8 ft drop

Electrical Cable

2,5 m drop 8 ft drop

## FINISHES

## WOOD VENEER

- |   |                   |   |              |
|---|-------------------|---|--------------|
|  | 20 Ivory White    |  | 26 Red       |
|  | 21 Natural Cherry |  | 28 Blue      |
|  | 22 Natural Beech  |  | 29 Grey      |
|  | 24 Yellow         |  | 33 Pale Rose |
|  | 25 Orange         |  | 34 Sea Blue  |

## LIGHT SOURCE

120 - 277V

LED Integrated

Dimmable 0-10V, Bluetooth or DALI

Class I 

120 - 277V

LED Integrated

Dimmable 0-10V &amp; TRIAC



● CARAMBOLA - SMALL SUSPENSION  
21 Natural Cherry Wood Veneer.  
"Caro" Hotel. Valencia, Spain.



# MINI CHOU



## Mini Chou

Designed by:  
Yonoh Creative Studio

The simplicity and charm of the Mini Chou, inspired by the traditional Japanese lantern called chou-chin, is able to capture the enchantment of the moment through light.

Mini Chou is the perfect companion for modern life: wireless, handy and exceptionally versatile. Handmade in natural wood veneer in Spain, Mini Chou has a dimmer that allows you to create the level of intimacy required.

With a whole world to discover, just how far will your Mini Chou take you?

- **MINI CHOU - CORDLESS TABLE**  
20 Ivory White Wood Veneer.  
"Refugio en la Viña". Valencia, Spain. Architect: Ramón Esteve Estudio.



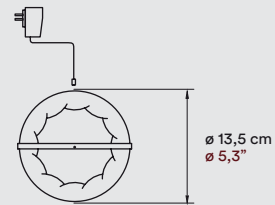
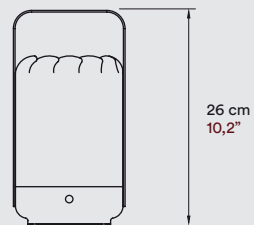

**MATERIALS & COMPONENTS**

Wood Veneer Shade

Acrylic Diffuser

Metal Base & Handle

**Rechargeable Battery**  
8 Hours Autonomy at 90% Power

**IN Charge**  
USB type C

On / Off Dimming

**LIGHT SOURCE**

LED Integrated Dimmable

Class III

LED Integrated Dimmable

**FINISHES**

**WOOD VENEER**

- 20 Ivory White
- 29 Grey
- 22 Natural Beech
- 33 Pale Rose
- 26 Red
- 34 Sea Blue
- \*On Request: 24 Yellow



● **MINI CHOU - CORDLESS TABLE**  
22 Natural Beech Wood Veneer.





# CHOU



- **CHOU - TALL TABLE**  
21 Natural Cherry Wood Veneer.  
"Palau de Casavells". Girona, Spain.

## Chou

Table

Designed by:  
Yonoh Creative Studio

Designed by Yonoh Creative Studio, the Chou lamp is available in two table versions. This deceptively simple light is especially pleasing when presented in a cluster of differing sizes. The Chou lamp catches the eye with its carefully considered pose.

CHOU

TABLE

YONOH CREATIVE STUDIO

SHORT

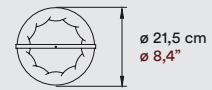
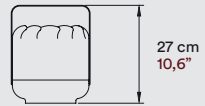

TALL

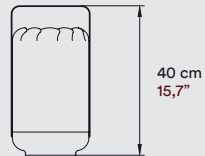

### MATERIALS & COMPONENTS

Wood Veneer Shade

Metal Base & Handle

Electrical Cable with Dimming Switch  
130 cm 49"

### LIGHT SOURCE

220 - 250V  
Bulb E27

Class II

120V  
Bulb E26



### FINISHES

#### WOOD VENEER

- |                   |              |
|-------------------|--------------|
| 20 Ivory White    | 26 Red       |
| 21 Natural Cherry | 28 Blue      |
| 22 Natural Beech  | 29 Grey      |
| 24 Yellow         | 33 Pale Rose |
| 25 Orange         | 34 Sea Blue  |

### AWARDS



Germany



- CHOU - SHORT TABLE  
33 Pale Rose Wood Veneer.  
"Palau de Casavells". Girona, Spain.



# C

# U



# A

## Cuad

Designed by:  
Burkhard Dämmer

• **CUAD - SUSPENSION**  
21 Natural Cherry Wood Veneer. "MSK Koch Center" Hospital. NY, USA. Photography: Chris Cooper.

The Cuad light is an architecturally pertinent pendant and one that illuminates a space with equanimity. The Cuad's wood veneer cuboid shape recalls the spirit of midcentury modern style with an understated elegance. Yet beneath that calm exterior, powerful electronic technology works with tremendous fervour to ensure that Cuad delivers its versatile light across a range of interior environments.

# D

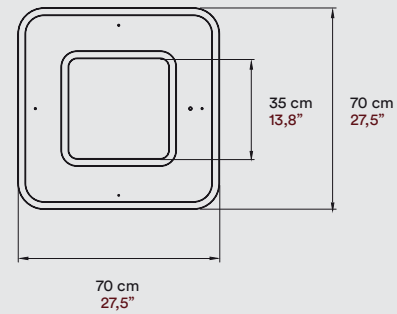
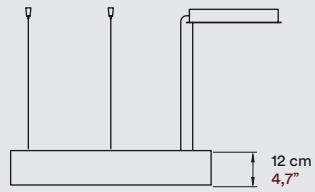

## MATERIALS & COMPONENTS

### Wood Veneer Shade

### Top & Bottom Acrylic Diffuser

### Metal Canopy

### Electrical Cable

2,5 m drop 8 ft drop

### 4 Steel Cables

2,5 m drop 8 ft drop

## LIGHT SOURCE

### 120 - 277V

LED Integrated  
Dimmable 0-10V, Bluetooth or DALI

Class I 

### 120 - 277V

LED Integrated  
Dimmable 0-10V & TRIAC



## FINISHES

### WOOD VENEER

	20 Ivory White		26 Red
	21 Natural Cherry		28 Blue
	22 Natural Beech		29 Grey
	24 Yellow		33 Pale Rose
	25 Orange		34 Sea Blue



- **CUAD - SUSPENSION**  
21 Natural Cherry Wood Veneer.  
"Villa El Nido". Marbella, Spain.  
Architects: A-cero Architects.
- **CUAD - SUSPENSION**  
21 Natural Cherry Wood Veneer.





---

D

A

N

D

---

## Dandelion

Designed by:  
Burkhard Dämmer

---

Bearing a resemblance to its flowering namesake, this lamp is a radiant composite of many single florets. Independent and distinct, each funnel-shaped floret appears to shine alone, yet en masse they create the Dandelion's sparkle.

• DANDELION - SUSPENSION  
26 Red Wood Veneer.



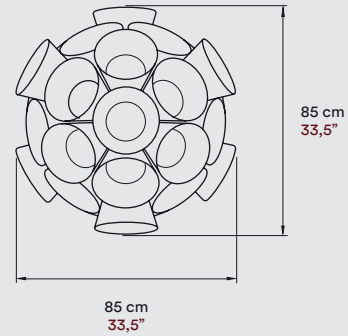
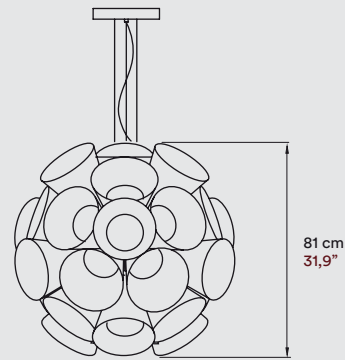

## MATERIALS & COMPONENTS

### Wood Veneer Shade

### Acrylic Diffusers

### Metal Canopy

### 3 Steel Cables





2,5 m drop 8 ft drop

### Electrical Cable

2,5 m drop 8 ft drop

## FINISHES

### WOOD VENEER

	20 Ivory White		26 Red
	21 Natural Cherry		28 Blue
	22 Natural Beech		29 Grey
	24 Yellow		33 Pale Rose
	25 Orange		34 Sea Blue

## LIGHT SOURCE

### 120 - 277V

LED Integrated  
Dimmable 0-10V, Bluetooth or DALI

Class I 

### 120 - 277V

LED Integrated  
Dimmable 0-10V



Chicago



Germany



Brussels



• DANDELION - SUSPENSION  
24 Yellow Wood Veneer.



# Domo

Designed by:  
Rqr Studio



With its handsome form, Domo is reserved, strong and aesthetically presented. This lamp consists of two layers: an outer layer formed using four interlocking timber veneer slats and an inner layer fashioned from seamless veneer joints. In history, the dome is a structure that exhibits strength. It is therefore fitting that Domo is an earnest light, with an inner flame and passion that truly shines.

Domo reflects light downwards and is perfect for a variety of tasks and chores. Pure, simple and practical, Domo is delightfully earnest.

• **DOMO - SUSPENSION** | 21 Natural Cherry Wood Veneer.



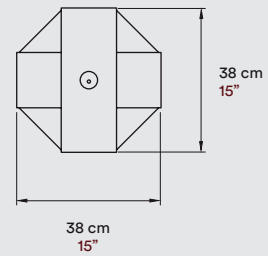
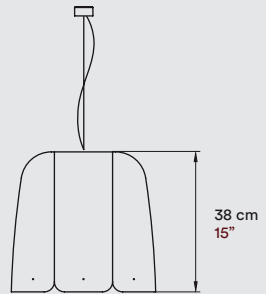

## MATERIALS & COMPONENTS

### Wood Veneer Shade

### Metal Canopy

### Steel Cable

2,5 m drop 8 ft drop

### Electrical Cable

2,5 m drop 8 ft drop

## LIGHT SOURCE

220 - 250V

Bulb E27

Class I

120 - 277V

Bulb E26



## FINISHES

### WOOD VENEER

	20 Ivory White		26 Red
	21 Natural Cherry		28 Blue
	22 Natural Beech		29 Grey
	24 Yellow		33 Pale Rose
	25 Orange		34 Sea Blue

### • DOMO - SUSPENSION

24 Yellow Wood Veneer.



### • DOMO - SUSPENSION

20 Ivory White Wood Veneer.





# Escape

Designed by:  
Ray Power

Small  
Large

# ESCAPE

Escape is an avant-garde pendant with a smart domino-like structure. Its self-supporting veneer panels give the impression of falling into a ring of light, their form defying gravity.

Designed by Ray Power, Escape is a truly handsome, self-assured light. While enjoying a little bit of swagger and appearing fairly pleased with itself, the Escape pendant's manner is bright and buoyant. Moreover, Escape is entirely affable, having an approachable quality that is perfect for any well turned out setting.

- **ESCAPE - SMALL SUSPENSION**  
20 Ivory White Wood Veneer.

## ESCAPE

## SUSPENSION

## RAY POWER

### SMALL

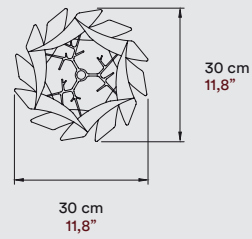
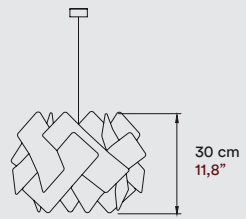

### LARGE

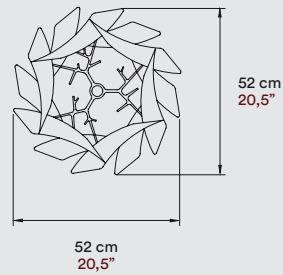
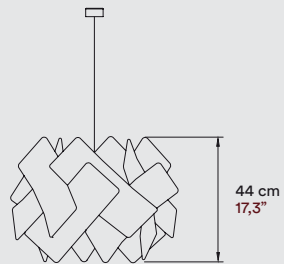

## MATERIALS & COMPONENTS

### Wood Veneer Shade

### Metal Tripod & Canopy

### Electrical Cable

2,5 m drop 8 ft drop

## LIGHT SOURCE

220 - 250V  
Bulb E27

Class I

120 - 277V  
Bulb E26

## AWARDS



Chicago

## FINISHES

### WOOD VENEER

- |  |                   |  |              |
|--|-------------------|--|--------------|
|  | 20 Ivory White    |  | 26 Red       |
|  | 21 Natural Cherry |  | 28 Blue      |
|  | 22 Natural Beech  |  | 29 Grey      |
|  | 24 Yellow         |  | 33 Pale Rose |
|  | 25 Orange         |  | 34 Sea Blue  |

### METAL CANOPY

- |  |               |  |                |
|--|---------------|--|----------------|
|  | BK-Matt Black |  | NI-Matt Nickel |
|  | WH-Matt White |  |                |

- ESCAPE - SMALL & LARGE SUSPENSION  
33 Pale Rose Wood Veneer.  
"La Monella" Jewellers.  
Valencia, Spain.

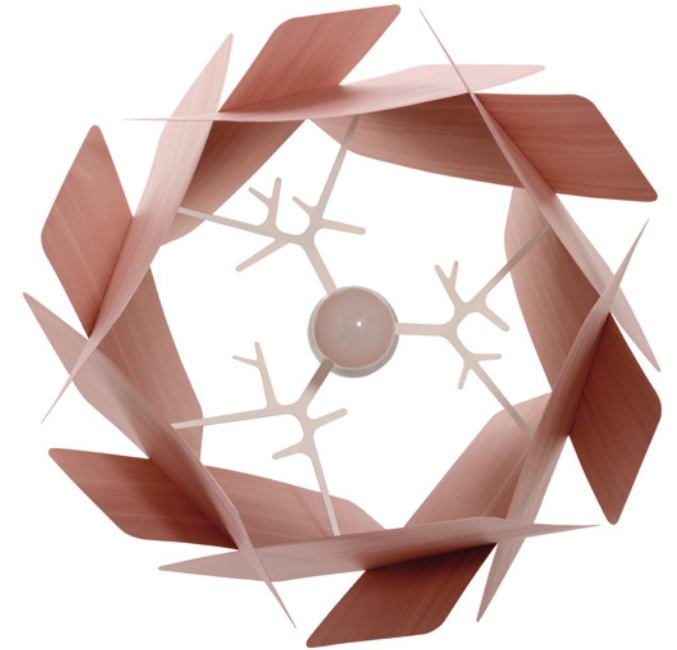



# GEA COSMOS

Suspension  
Floor  
Wall  
Ceiling

Designed by:  
Mariví Calvo



• GEA - LARGE SUSPENSION | 29 Grey Wood Veneer. Photo: 4000k.

A versatile all-rounder, Gea is a solid and circular suspension, ceiling, wall and floor lamp (named 'Cosmos'). Gea's modest form is smart, self-possessed and clean-cut. A steadfast performer, Gea radiates warmth from its wood veneer sides, the resulting effect satisfyingly serene.

We find a light that is unpretentious and yet highly accomplished, its versatility knowing no bounds. From a series of Super Gea pendants hanging in the hallways of power to a Gea ceiling lamp fixed in a minimalist space, this appealing light is reassuringly loyal.



• GEA - LARGE SUSPENSION | 29 Grey Wood Veneer. "Le Meridien" Hotel. Tarragona, Spain. Photo: 4000k.

## SMALL

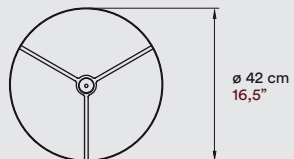
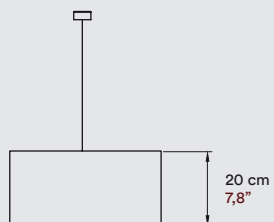

## LARGE

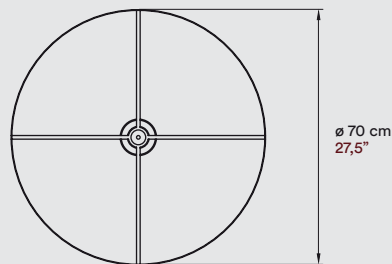
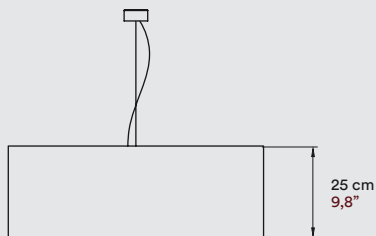

## MATERIALS &amp; COMPONENTS

Wood Veneer Shade

Acrylic Diffuser

Metal Tripod &amp; Canopy

Steel Cable



2,5 m drop 8 ft drop Only in Large size

Electrical Cable

2,5 m drop 8 ft drop

## FINISHES

## WOOD VENEER

	20 Ivory White		26 Red
	21 Natural Cherry		28 Blue
	22 Natural Beech		29 Grey
	24 Yellow		33 Pale Rose
	25 Orange		34 Sea Blue

## LIGHT SOURCE

220 - 250V

Class I 

SMALL Bulb E27

LARGE 3 Bulbs E27

120 - 277V



SMALL Bulb E26

LARGE 3 Bulbs E26

## SLIM

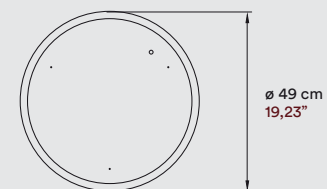
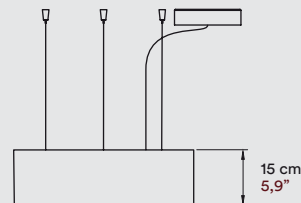

## MATERIALS &amp; COMPONENTS

Wood Veneer Shade

Top &amp; Bottom Acrylic Diffuser

Metal Canopy

3 Steel Cables











2,5 m drop 8 ft drop

Electrical Cable

2,5 m drop 8 ft drop

## FINISHES

## WOOD VENEER

	20 Ivory White		26 Red
	21 Natural Cherry		28 Blue
	22 Natural Beech		29 Grey
	24 Yellow		33 Pale Rose
	25 Orange		34 Sea Blue

## LIGHT SOURCE

120 - 277V

Class I 

LED Integrated

Dimmable 0-10V, Bluetooth or DALI

120 - 277V



LED Integrated

Dimmable 0-10V &amp; TRIAC



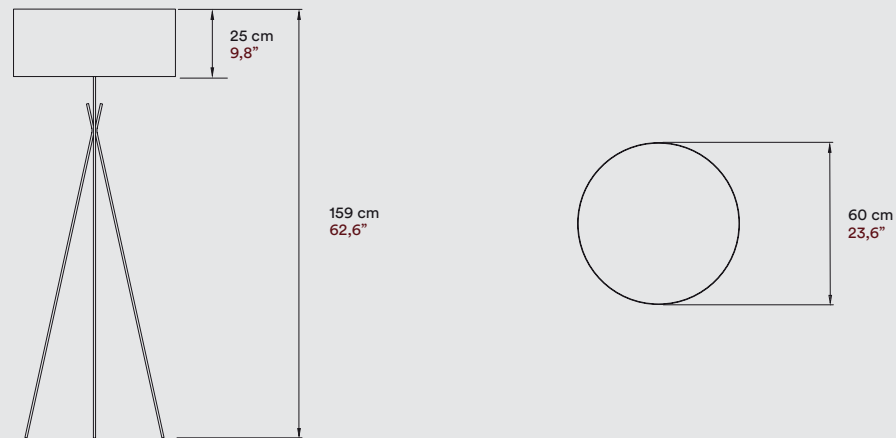

## MATERIALS & COMPONENTS

Wood Veneer Shade



Acrylic Upper Diffuser

Metal Tripod & Base

Electrical Cable with Dimming Switch  
185 cm 53"

## LIGHT SOURCE

220 - 250V  
3 Bulbs E27



Class II  

120V  
3 Bulbs E26



## FINISHES

### WOOD VENEER

- |   |  |
|---|--|
|  20 Ivory White    |  26 Red       |
|  21 Natural Cherry |  28 Blue      |
|  22 Natural Beech  |  29 Grey      |
|  24 Yellow         |  33 Pale Rose |
|  25 Orange         |  34 Sea Blue  |



• COSMOS - FLOOR | 20 Ivory White.  
"Villa El Nido". Architects. A-cero. Marbella, Spain.

**SMALL**

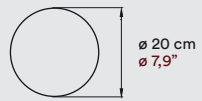

**MEDIUM**

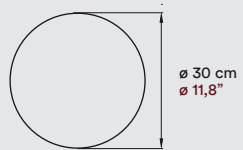

**LARGE**

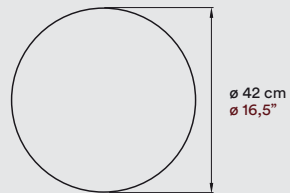

**MATERIALS & COMPONENTS**

Wood Veneer Shade

Acrylic Frontal Diffuser

Metal Back plate

**LIGHT SOURCE**

**120 - 277V**  
LED Integrated  
Dimmable 0-10V  
or  
**220 - 250V**  
Bulb GX53

Class I

**120 - 277V**  
LED Integrated  
Dimmable 0-10V & TRIAC  
or  
**120V**  
Bulb GX53

ADA Compliant

**FINISHES**

**WOOD VENEER**

- |                   |              |
|-------------------|--------------|
| 20 Ivory White    | 26 Red       |
| 21 Natural Cherry | 28 Blue      |
| 22 Natural Beech  | 29 Grey      |
| 24 Yellow         | 33 Pale Rose |
| 25 Orange         | 34 Sea Blue  |



• **GEA LARGE CEILING**  
29 Grey Wood Veneer.  
Photo: 4000k.  
"Le Meridien" Hotel.  
Tarragona, Spain.



• **GEA - SMALL, MEDIUM & LARGE WALL**  
29 Grey Wood Veneer.  
Photo: 4000k.  
"Le Meridien" Hotel.  
Tarragona, Spain.



# Guijarro

Designed by:  
Mariví Calvo

J

A

G

U

I

R



R

Guijarro is a family of three pebble-like lights, each one perfect for use on a wall or ceiling. This lamps were inspired by fine shingle: small, smooth and rounded pebbles whose individual shapes have been carved over many years by water and sand. A tiny wonder of nature, every pebble exhibits its own colour, contours and form.

With three different sizes and a choice of wood veneer finishes, the Guijarro lights are especially eye-catching when displayed in a group formation. Just as pebbles live in harmony, present a strong sense of oneness.

- GUIJARRO - SMALL, MEDIUM & LARGE  
21 Natural Cherry, 24 Yellow & 29 Grey Wood Veneer.

O

GUIJARRO

WALL & CEILING

MARIVÍ CALVO

SMALL

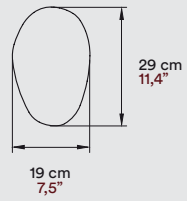

MEDIUM

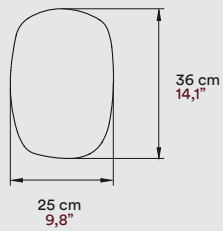

LARGE

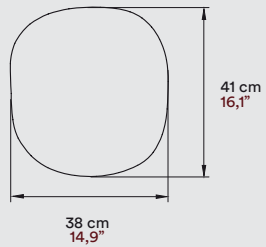

MATERIALS & COMPONENTS

Wood Veneer Shade

Acrylic Frontal Diffuser

Metal Back Plate

LIGHT SOURCE

120 - 277V  
LED Integrated  
Dimmable 0-10V  
or  
220 - 250V  
Bulb GX53

Class I

120 - 277V  
LED Integrated  
Dimmable 0-10V & TRIAC  
or  
120V  
Bulb GX53



ADA Compliant

FINISHES

WOOD VENEER

- |                   |              |
|-------------------|--------------|
| 20 Ivory White    | 26 Red       |
| 21 Natural Cherry | 28 Blue      |
| 22 Natural Beech  | 29 Grey      |
| 24 Yellow         | 33 Pale Rose |
| 25 Orange         | 34 Sea Blue  |



● GUIJARRO - LARGE WALL  
21 Natural Cherry Wood Veneer. "Mad Mouse" Coworking. Valencia, Spain.



# HI-COLLAR

## Hi-Collar

Designed by:  
Ray Power

Inspired by the traditional stiff shirt collar of old, Ray Power designed the Hi-Collar wall light. This small and simple lamp casts an indirect light in subdued tones both upwards and downwards, while the single piece of bent wood veneer diffuses a warming glow. There is no preening or primping, just a straightforward, minimalistic and unobtrusive light. It is a light perfectly suited to quiet spaces in homes and hotels, studios and eateries.

● HI-COLLAR - WALL | 20 Ivory White Wood Veneer. "Le Meridien" Hotel. Tarragona, Spain.



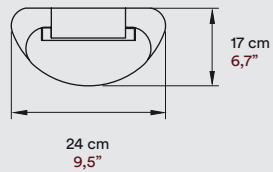
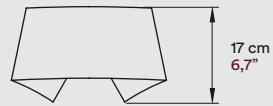

**MATERIALS & COMPONENTS**

Wood Veneer Shade

Metal Back Plate

**LIGHT SOURCE**

120 - 277V  
LED Integrated  
Dimmable 0-10V

Class I

120 - 277V  
LED Integrated  
Dimmable 0-10V & TRIAC

US

**FINISHES**

**WOOD VENEER**

- |                   |              |
|-------------------|--------------|
| 20 Ivory White    | 26 Red       |
| 21 Natural Cherry | 28 Blue      |
| 22 Natural Beech  | 29 Grey      |
| 24 Yellow         | 33 Pale Rose |
| 25 Orange         | 34 Sea Blue  |



● **HI-COLLAR - WALL** | 33 Pale Rose Wood Veneer.  
"La Monella" Jewelers. Valencia, Spain.



# I — CLUB

Designed by:  
Burkhard Dämmer

Created by Burkhard Dämmer, the I-Club is designed with clean architectural lines and a longer form that will illuminate its surroundings with understated elegance. An innovative lighting series, I-Club has a symmetrical beauty that is replicated across a number of models: suspension, wall, ceiling, floor and table.

## I-Club

Suspension  
Ceiling  
Wall  
Table



I-CLUB SUSPENSION | 21 Natural Cherry Wood Veneer. © MSK Koch Center Hospital, NY, USA. Photography: Chris Cooper.



## SHORT SLIM

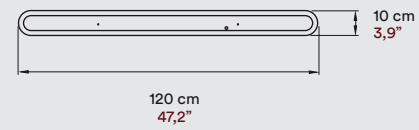
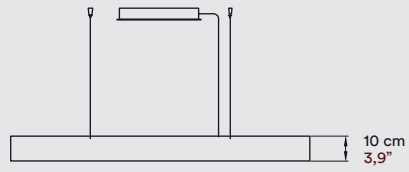

## LONG SLIM

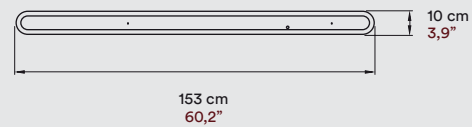
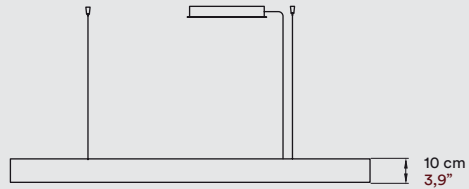

## MATERIALS &amp; COMPONENTS

## Wood Veneer Shade

## Top &amp; Bottom Acrylic Diffuser

## Metal Canopy

## 2 Steel Cables









2,5 m drop 8 ft drop

## Electrical Cable

2,5 m drop 8 ft drop

## FINISHES

## WOOD VENEER

	20 Ivory White		26 Red
	21 Natural Cherry		28 Blue
	22 Natural Beech		29 Grey
	24 Yellow		33 Pale Rose
	25 Orange		34 Sea Blue

## LIGHT SOURCE

## 120 - 277V

LED Integrated  
Dimmable 0-10V, Bluetooth or DALIClass I 

## 120 - 277V

LED Integrated  
Dimmable 0-10V & TRIAC

- **I-CLUB SLIM - SUSPENSION**  
21 Natural Cherry Wood Veneer.  
"Villa El Nido". Marbella, Spain.  
Architects: A-cero Atchitects.

- **I-CLUB - TABLE**  
21 Natural Cherry Wood Veneer.

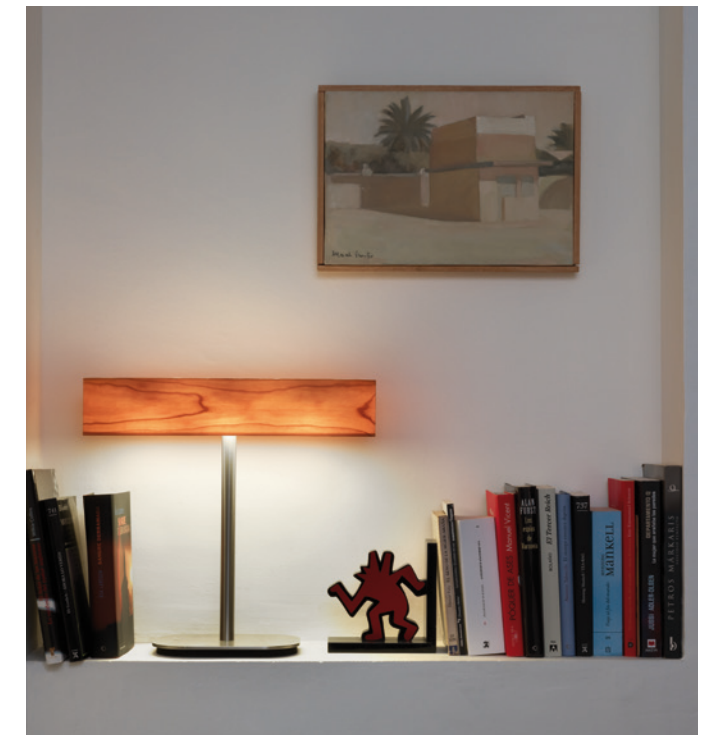



I-CLUB

WALL

BURKHARD DÄMMER

SMALL

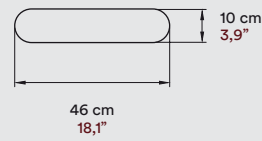
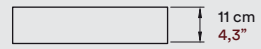

SLIM



## MATERIALS & COMPONENTS

Wood Veneer Shade

Bottom & Upper Acrylic Diffuser

Metal Back Plate

## LIGHT SOURCE

**120 - 277V**  
LED Integrated  
Dimmable 0-10V, Bluetooth or DALI

Class I

**120 - 277V**  
LED Integrated  
Dimmable 0-10V & TRIAC

PENDING

ADA Compliant

## FINISHES

### WOOD VENEER

- |                   |              |
|-------------------|--------------|
| 20 Ivory White    | 26 Red       |
| 21 Natural Cherry | 28 Blue      |
| 22 Natural Beech  | 29 Grey      |
| 24 Yellow         | 33 Pale Rose |
| 25 Orange         | 34 Sea Blue  |



● **I-CLUB - SMALL WALL**  
21 Natural Cherry Wood Veneer.  
"Caro" Hotel. Valencia, Spain.

● **I-CLUB SLIM - WALL**  
21 Natural Cherry Wood Veneer.  
"Palau de Casavells". Girona, Spain.

## LARGE



## MATERIALS &amp; COMPONENTS

Wood Veneer Shade

Frontal Acrylic Diffuser

Metal Back Plate

## LIGHT SOURCE

**120 - 277V**  
LED Integrated  
Dimmable 0-10V, Bluetooth or DALI

Class I 

**120 - 277V**  
LED Integrated  
Dimmable 0-10V or TRIAC



## FINISHES

## WOOD VENEER

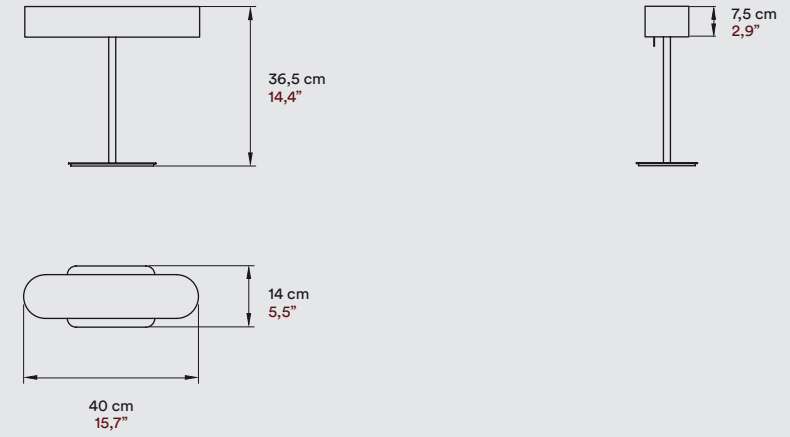

## MATERIALS &amp; COMPONENTS

Wood Veneer Shade

Bottom &amp; Upper Acrylic Diffuser

Metal Stem &amp; Base

Touch on/off Dimming Rod

**Electrical Cable**  
145 cm 57"

## LIGHT SOURCE

LED Integrated Dimmable

LED Integrated Dimmable

Class II 

## FINISHES

## WOOD VENEER





# LENS

## Lens

Wall  
Floor  
Table

Designed by:  
Mut Design



- **LENS**  
33 Pale Rose Wood Veneer & Gold Metal Structure.

Designed by MUT, Lens enjoys flowing lines with no hard edges. Its wood veneer shade surrounds an oval circumference of light, and in its centre is a clear void. The shade is connected to a slender metallic base. Available as a table and floor lamp, Lens has two shade types: circular and elliptic. The elliptic version has two shapes: an elongated ellipse and a truncated ellipse.

Free from interruption, Lens's radiant light traces the air. Perfectly symmetrical and sleek, soothing and suave, Lens is one smooth luminaire.



- **LENS - FLOOR SUPER OVAL & OVAL**  
21 Natural Cherry Wood Veneer & Matt Black Metal Structure. "Casa en la Huerta". Valencia, Spain. Architect: Ramón Esteve Estudio.



● **LENS - TABLE CIRCULAR**  
20 Ivory White Wood Veneer & Gold Metal Structure.  
"Bouet" Restaurant. Valencia, Spain. Architect: Ramón Esteve Estudio.



● **LENS - TABLE OVAL**  
20 Ivory White Wood Veneer & Gold Metal Structure. "Casa en la Huerta". Valencia, Spain. Architect: Ramón Esteve Estudio.

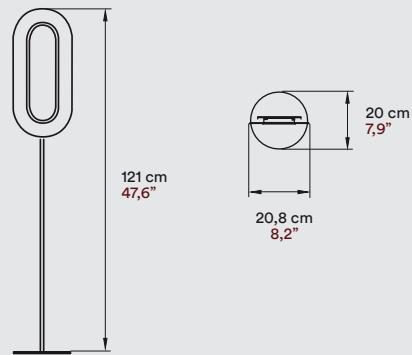
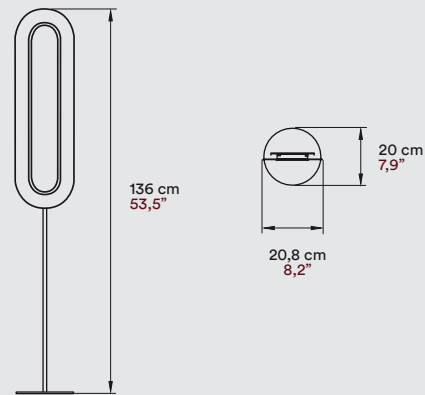
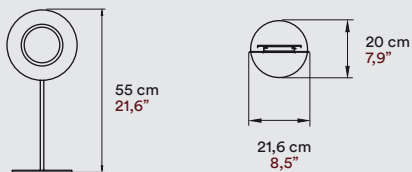
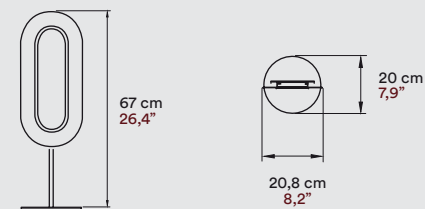
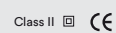

**LENS****FLOOR & TABLE****MUT DESIGN****FLOOR OVAL****FLOOR SUPER OVAL****TABLE CIRCULAR****TABLE OVAL****MATERIALS & COMPONENTS****Wood Veneer Shade****Metal Ring, Stem & Base****Electrical Cable with Dimming Switch****FLOOR** 185 cm 73"**TABLE** 145 cm 57"**LIGHT SOURCE****230V**  
LED Integrated Dimmable.**120V**  
LED Integrated Dimmable.**FINISHES****WOOD VENEER**

- 20 Ivory White
- 28 Blue
- 21 Natural Cherry
- 29 Grey
- 22 Natural Beech
- 33 Pale Rose

**METAL**

- IV-Matt Ivory
- NI-Matt Nickel
- BK-Matt Black
- GD-Gold

**• LENS - TABLE OVAL**

20 Ivory White Wood Veneer &amp; Ivory White Metal Structure.

"Goded" Housing. Valencia, Spain. Project: Raw Arquitectura. Photography: Cualiti Photo Studio. Furniture: Annud.

# LI



• **LINK - LARGE SUSPENSION**  
21 Natural Cherry Wood Veneer.  
"Bachelor loft". Toronto, Canada.  
Design: Stephane Chamard.  
Photographie by Lisa Petrole.

## Link

Small Suspension  
Large Suspension  
Floor

Designed by:  
Ray Power

Designed by Ray Power, Link appears exceptionally dashing in its stacked wood veneer Möbius strips. In mathematics, the Möbius strip is a surface with one continuous side, meaning the Link light is not only handsome, but discerning too.

With its billowy, cloud-like structure, Link is decidedly easy on the eye. Punctiliously crafted, the lamp's floating form is a clever illustration of wood's significant potential in lighting design. Link is available as a suspension lamp in three versions: small, large and modular. In addition, Link is an attractive floor lamp, its billowy mass poised on the top of a chrome tower-like base.

In Link, there is an obvious 'link' between brilliance and beauty, form and function.

# INK



**LINK** **SUSPENSION** **RAY POWER**

**SMALL**

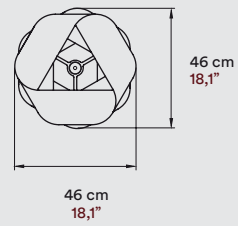
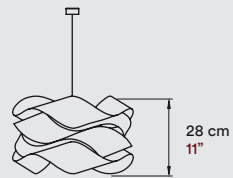

**LARGE**

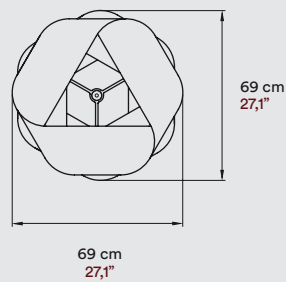
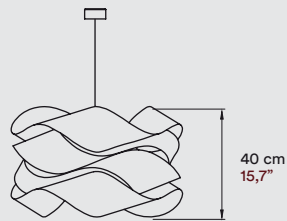

**MATERIALS & COMPONENTS**

**Wood Veneer Shade**

**Metal Tripod & Canopy**

**Electrical Cable**  
2,5 m drop 8 ft drop

**LIGHT SOURCE**

**220 - 250V** Class I Bulb E27

**120 - 277V** Bulb E26

**AWARDS**

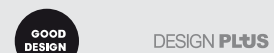

Chicago Frankfurt

**FINISHES**

**WOOD VENEER**

- 20 Ivory White
- 26 Red
- 21 Natural Cherry
- 28 Blue
- 22 Natural Beech
- 29 Grey
- 24 Yellow
- 33 Pale Rose
- 25 Orange
- 34 Sea Blue

**METAL CANOPY**

- BK-Matt Black
- NI-Matt Nickel
- WH-Matt White



● **LINK - LARGE SUSPENSION**  
20 Ivory White Wood Veneer.  
"Ladon Restaurant", Spain.  
Photography: estudi{H}ac.

● **LINK - LARGE SUSPENSION**  
24 Yellow Wood Veneer.  
Architects: Luca Construction and Design.  
Inc Pennsylvania.

**LINK CHAIN****SUSPENSION**

RAY POWER &amp; MARIVÍ CALVO

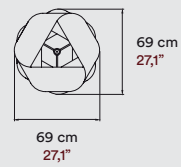
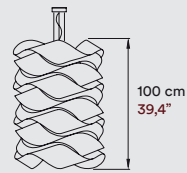
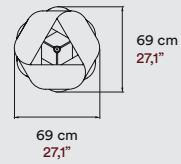
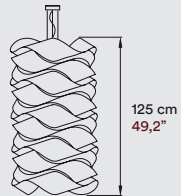
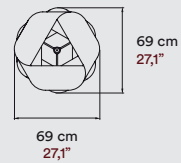
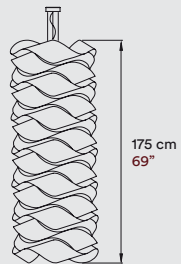
**SMALL****MEDIUM****LARGE****MATERIALS & COMPONENTS**

Wood Veneer Shade

Metal Tripod &amp; Canopy

3 Steel Cables  
2,5 m drop 8 ft dropElectrical Cable  
2,5 m drop 8 ft drop**LIGHT SOURCE**220 - 250V  
3, 4 or 6 Bulbs E27

Class I

120 - 277V  
3, 4 or 6 Bulbs E26**FINISHES****WOOD VENEER**

- |                   |              |
|-------------------|--------------|
| 20 Ivory White    | 26 Red       |
| 21 Natural Cherry | 28 Blue      |
| 22 Natural Beech  | 29 Grey      |
| 24 Yellow         | 33 Pale Rose |
| 25 Orange         | 34 Sea Blue  |



- **LINK CHAIN LARGE - SUSPENSION**  
20 Ivory White Wood Veneer.  
HVB Freising Invest by Bottler & Luts Architekten BDA.

- **LINK CHAIN SMALL - SUSPENSION**  
20 Ivory White Wood Veneer.  
"Petit Palace" Hotel. Madrid, Spain. Architect: Jesús Ángel Miranda.



As the Link Chain is a modular system, it allows for different lengths and combination of Link shade modules upon request.



LINK

FLOOR

RAY POWER

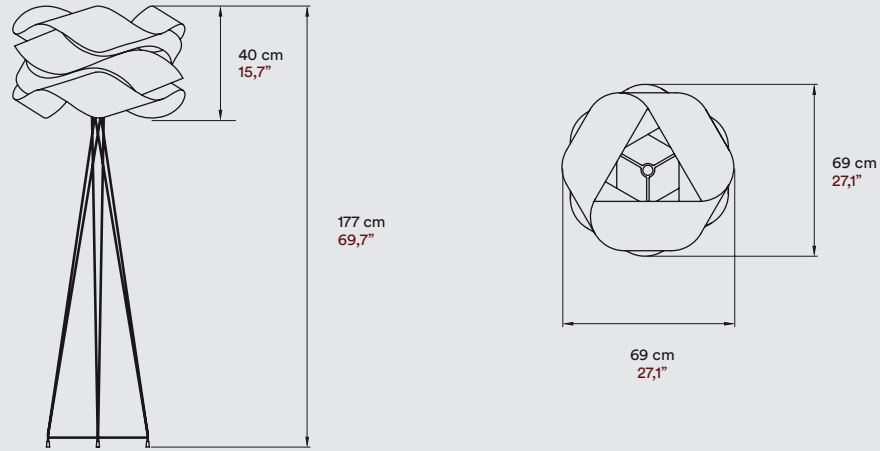

**MATERIALS & COMPONENTS**

Wood Veneer Shade

Metal Tripod & Base

Electrical Cable with Dimming Switch  
185 cm 53"

**LIGHT SOURCE**

220 - 250V  
Bulb E27

Class II

120V  
Bulb E26



**FINISHES**

**WOOD VENEER**

- 20 Ivory White
- 26 Red
- 28 Blue
- 21 Natural Cherry
- 29 Grey
- 22 Natural Beech
- 33 Pale Rose
- 24 Yellow
- 34 Sea Blue
- 25 Orange

**METAL**

- NI-Matt Nickel

● LINK - FLOOR  
21 Natural Cherry Wood Veneer.



● LINK - FLOOR | 24 Yellow Wood Veneer. "La Boscana" Restaurant. Spain. Architect: Jordi Font.



# LO

Designed by:  
Ray Power



## Lola

Suspension  
Floor  
Table  
Wall

Lola is the latest lamp for LZF designed by long-time collaborator Ray Power. Showcasing Power's ability to create imaginative three-dimensional forms, Lola is a conical lamp with an intricate geometric pattern. A veritable labour of love, Lola's shape went through many iterations, drawings and prototypes. The end result is, without doubt, a marvel of lighting design.

A particularly piquant Spanish name, Lola is very much alive, sensuous and intriguing. In a domestic or contract setting, Lola is a lamp that attracts and pleases the eye. Highly original and truly sophisticated, Lola's complex veneer construction is both accentuated and softened when illuminated. Available in a number of sizes and LZF's range of natural wood colours, Lola is stimulating, fascinating, arresting and sparkling: an especially piquant light.

- **LOLA MEDIUM SUSPENSION**  
22 Natural Beech Wood Veneer.  
"Palau de Casavells", Girona, Spain.

# LA



LOLA

SUSPENSION

RAY POWER

MEDIUM

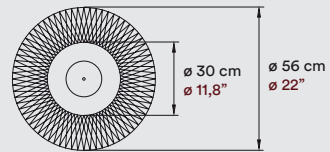
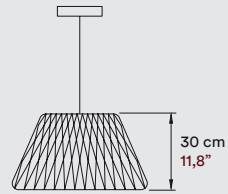

LARGE

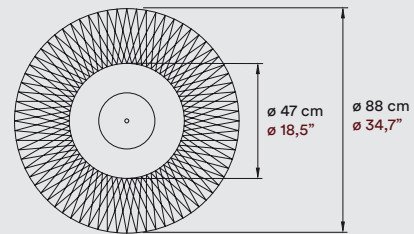
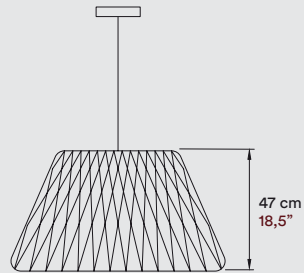

## MATERIALS & COMPONENTS

Woven Wood Veneer Shade

Acrylic Frame

Metal Canopy

Electrical Cable

2,5 m drop 8 ft drop

## LIGHT SOURCE

120 - 277V

LED Integrated  
Dimmable 0-10V, Bluetooth or DALI

Class I 



120 - 277V

LED Integrated  
Dimmable 0-10V & TRIAC





## FINISHES

WOOD VENEER

-  20 Ivory White
-  29 Grey
-  22 Natural Beech

METAL CANOPY

-  BK-Matt Black
-  NI-Matt Nickel
-  WH-Matt White

## • LOLA - SUSPENSION

22 Natural Beech Wood Veneer.



LOLA

FLOOR

RAY POWER

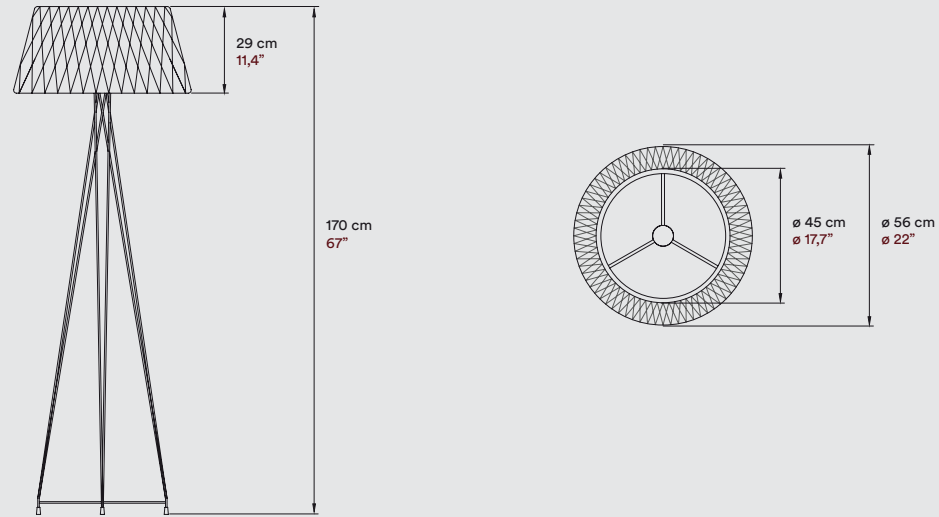

## MATERIALS & COMPONENTS

Woven Wood Veneer Shade

Acrylic Frame

Metal Foot

Electrical Cable with Dimming Switch  
185 cm 53"

## LIGHT SOURCE

220 - 250V  
Bulb E27

Class II

120V  
Bulb E26



160

## FINISHES

### WOOD VENEER

- 20 Ivory White
- 29 Grey
- 22 Natural Beech

### METAL

- IV-Matt Ivory
- NI-Matt Nickel
- BK-Matt Black
- GD-Gold

● LOLA - FLOOR  
22 Natural Beech Wood Veneer.

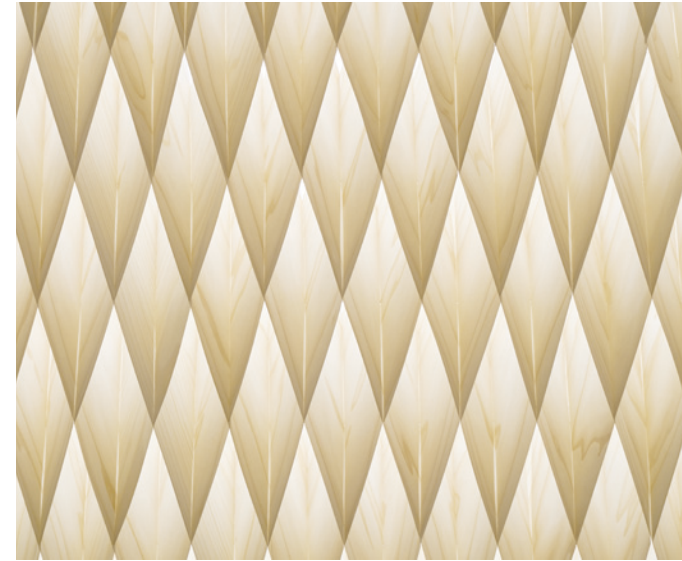

● LOLA - FLOOR  
20 Ivory White Wood Veneer & Matt Black Metal Foot. Photo: 4000k.  
"Casa en la Huerta". Valencia, Spain. Architect: Ramón Esteve Estudio.



LOLA

TABLE

RAY POWER

SMALL

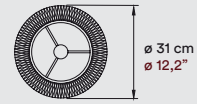
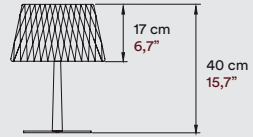

MEDIUM

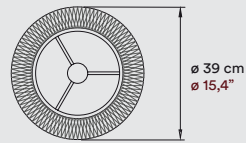
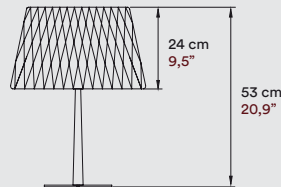

### MATERIALS & COMPONENTS

Woven Wood Veneer Shade

Acrylic Frame

Metal or Marble Foot

Electrical Cable with Dimming Switch  
145 cm 57"

### LIGHT SOURCE

220 - 250V  
Bulb E27



Class II  

120V  
Bulb E26







### FINISHES

#### WOOD VENEER

-  20 Ivory White
-  29 Grey
-  22 Natural Beech

#### METAL

-  IV-Matt Ivory
-  NI-Matt Nickel
-  BK-Matt Black
-  GD-Gold

#### • LOLA - TABLE MEDIUM

22 Natural Beech Wood Veneer & Matt Black Metal Foot.  
"Casa en la Huerta". Valencia, Spain.  
Architect: Ramón Esteve Estudio.



#### • LOLA - TABLE MEDIUM

20 Ivory White Wood Veneer &  
Ivory White, Matt Black & Gold Metal.





● **LOLA LUX LARGE** | 20 Ivory White Wood Veneer & Black Marble Base. "Cosin" Workspace. Valencia, Spain.



LOLA

LUX TABLE

RAY POWER

MEDIUM LUX

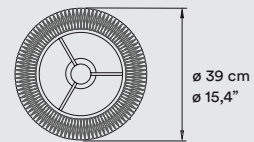
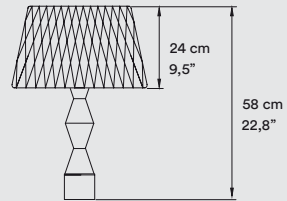

LARGE LUX

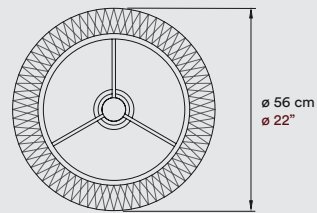
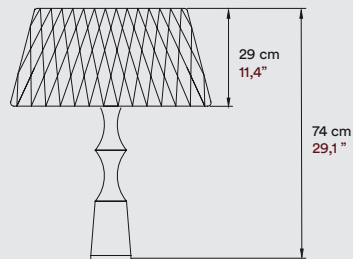

MATERIALS & COMPONENTS

Woven Wood Veneer Shade

Acrylic Frame

Marble Foot

Electrical Cable with Dimming Switch  
145 cm 57"

LIGHT SOURCE

220 - 250V  
Bulb E27

Class II

120V  
Bulb E26

FINISHES

WOOD VENEER

- 20 Ivory White
- 29 Grey
- 22 Natural Beech

MARBLE LOLA LARGE LUX

- Black "Marquina" Marble



• LOLA LUX MEDIUM | 20 Ivory White Wood Veneer & Black Marble Base. "Caro Hotel". Valencia, Spain.

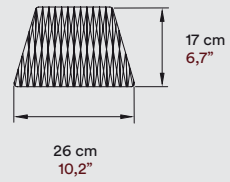

## MATERIALS & COMPONENTS

Woven Wood Veneer Shade

Acrylic Frame

Metal Back Plate

## FINISHES

### WOOD VENEER

● 20 Ivory White

● 22 Natural Beech

## LIGHT SOURCE

**220 - 250V**  
2 Bulbs GX53

Class I 

**120 - 277V**  
2 Bulbs GX53

 US

ADA Compliant



● LOLA - WALL | 22 Natural Beech Wood Veneer. "Caro" Hotel. Valencia, Spain.



# MINIMIKADO



## MiniMikado

Designed by:  
Miguel Herranz

- **MINIMIKADO- SUSPENSION**  
24 Yellow Wood Veneer. "Villa El Nido". Marbella, Spain.



The Mikado light takes its names from the classic pick-up-sticks game, where sticks are bundled together and when released, fall in a circular jumble. A radiant light, Mikado's wood veneer strips spread outwards, in a manner evocative of a bird's plumage. Cleverly engineered, the Mikado's form is both chaotic and harmonious at the same time.

Designed by Miguel Herranz, the Mikado is a free spirit, possessing an air of nonchalance and a teasingly impish swagger. It is a light whose profile is like a coruscating kaleidoscope of pattern.

- **MINIMIKADO - SUSPENSION**  
20 Ivory White Wood Veneer. "Alameda" Restaurant. Madrid, Spain.



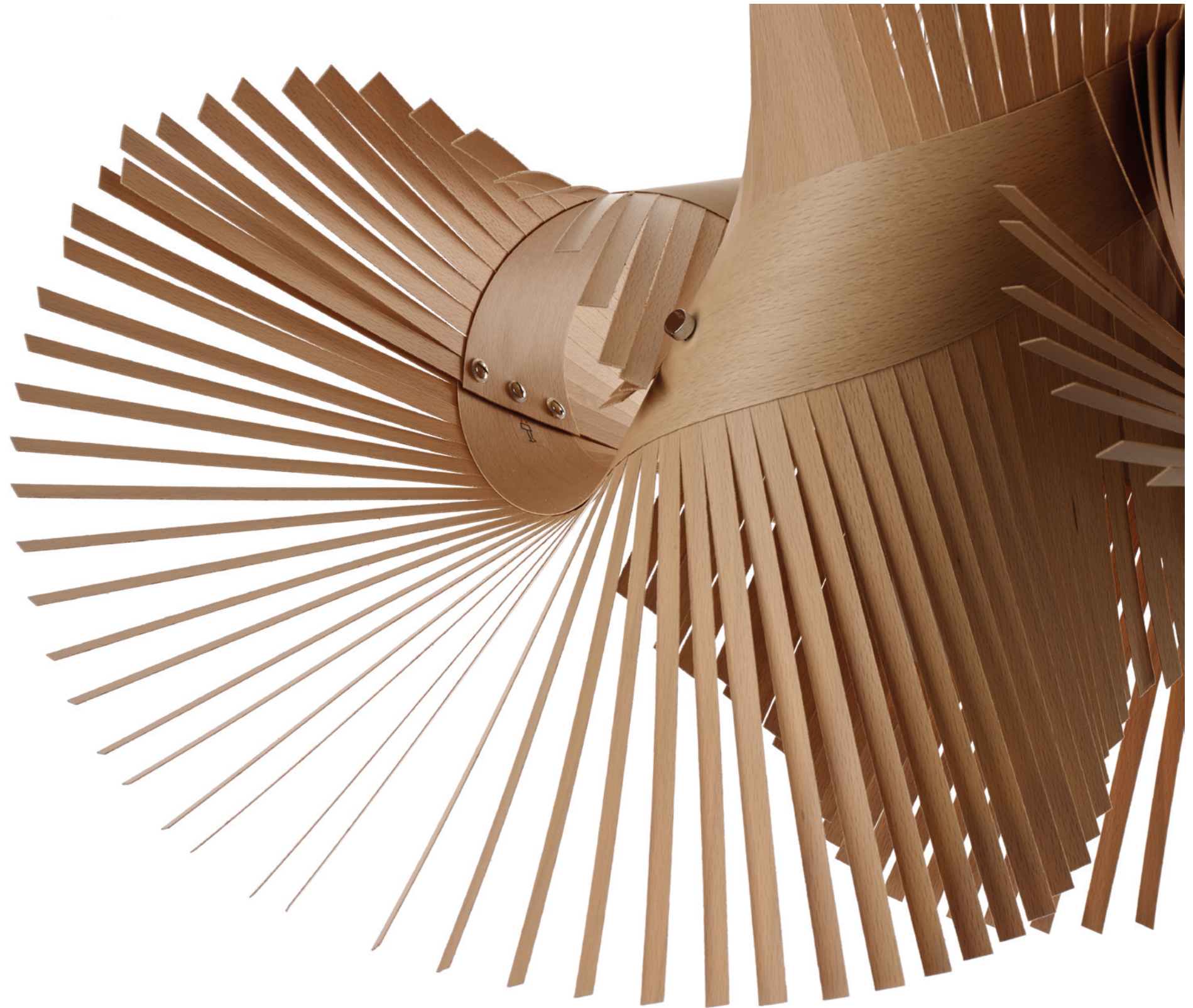

● **MINIMIKADO - SUSPENSION**  
22 Natural Beech Wood Veneer.



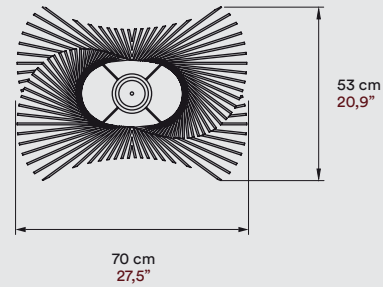
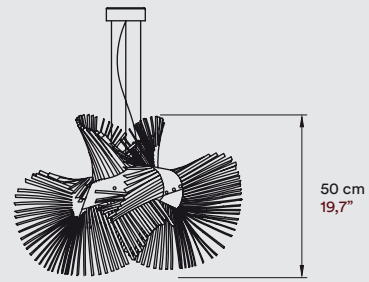

## MATERIALS & COMPONENTS

### Wood Veneer Shade

### Metal Structure & Canopy

### 3 Steel Cables

2,5 m drop 8 ft drop

### Electrical Cable

2,5 m drop 8 ft drop

## LIGHT SOURCE

220 - 250V

Bulb E27

Class I

120 - 277V

Bulb E26

US

## FINISHES

### WOOD VENEER

	20 Ivory White		26 Red
	21 Natural Cherry		28 Blue
	22 Natural Beech		29 Grey
	24 Yellow		33 Pale Rose
	25 Orange		34 Sea Blue

## AWARDS



Chicago

DESIGN PLUS

Frankfurt

## ● MINIMIKADO - SUSPENSION

22 Natural Beech Wood Veneer.

"Caro" Hotel. Valencia, Spain.



NEW



Designed by:  
Ray Power

New Wave comprises of two interlocking interior and exterior wood veneer sheets. Differing in colour to the exterior sheets, the interior sheets's edge juts out, creating a clever design feature that enhances the New Wave's profile. The resulting composition is well-proportioned and fluid, giving the New Wave a smooth, free-flowing countenance.

## New Wave

- **NEW WAVE - SUSPENSION**  
28 Blue & 24 Yellow Wood Veneer.  
"Ma Khin" Cafe. Valencia, Spain.

NEW



## NEW WAVE

## SUSPENSION

## RAY POWER

### LED

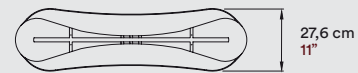
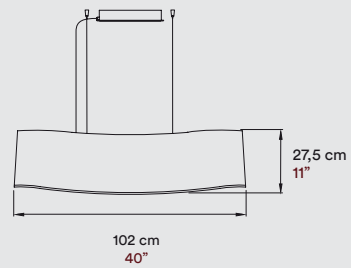

### BULBS

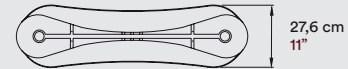
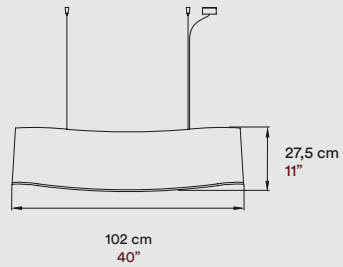

## MATERIALS & COMPONENTS

### Wood Veneer Shade

### Metal Structure & Canopy

#### 4 Steel Cables

2,5 m drop 8 ft drop

#### Electrical Cable

2,5 m drop 8 ft drop

## LIGHT SOURCE

### 120 - 277V

LED Integrated  
Dimmable 0-10V, Bluetooth or DALI  
or

### 220 - 250V

2 Bulbs E27

Class I

### 120 - 277V

LED Integrated  
Dimmable 0-10V & TRIAC  
or

### 120 - 277V

2 Bulbs E26



## FINISHES

### WOOD VENEER COMBINATIONS

#### Exterior



21 Cherry

with



20 Ivory White



26 Red

with



24 Yellow



28 Blue

with



24 Yellow

## AWARDS



Chicago



#### NEW WAVE - SUSPENSION

21 Natural Cherry & 20 Ivory White Wood Veneer.

#### NEW WAVE - SUSPENSION

26 Red & 20 Yellow Wood Veneer.  
Private Company Office. Madrid, Spain.



#### NEW WAVE - SUSPENSION

28 Blue & 24 Yellow Wood Veneer.

# NUT

## Nut

Designed by:  
Ray Power

Nut is an unfussy and modest knot of light, its elegant form made by the twisting and looping of wood veneer. A small and simple pendant, the Nut lamp is ideal when seeking to achieve a relaxed ambience.

The Nut lamp has two different forms, as determined by the direction of torsion—that is to say, the way in which the wood veneer is twisted.



- **NUT - SUSPENSION**  
22 Natural Beech Wood Veneer.  
“Malangen Retreat”. Architects: Snorre Stinessen Arkitektur Norway.



**NUT**

**SUSPENSION**

**RAY POWER**

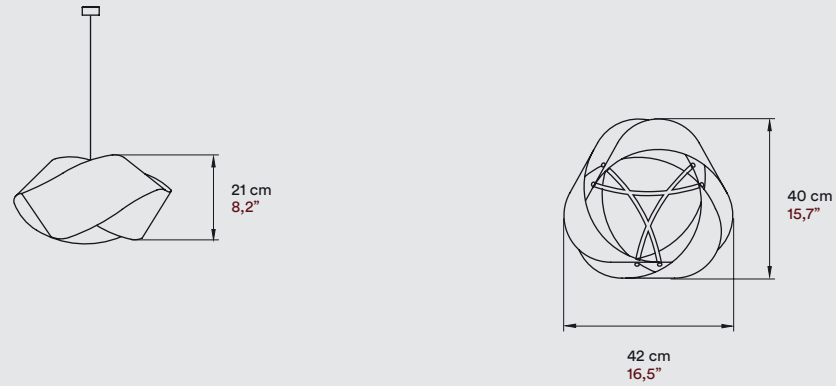

**MATERIALS & COMPONENTS**

Wood Veneer Shade

Metal Tripod & Canopy

Electrical Cable  
2,5 m drop 8 ft drop

**LIGHT SOURCE**

220 - 250V  
Bulb E27 Class I

120 - 277V  
Bulb E26

**FINISHES**

**WOOD VENEER**

- |                   |              |
|-------------------|--------------|
| 20 Ivory White    | 26 Red       |
| 21 Natural Cherry | 28 Blue      |
| 22 Natural Beech  | 29 Grey      |
| 24 Yellow         | 33 Pale Rose |
| 25 Orange         | 34 Sea Blue  |

**METAL CANOPY**

- |               |                |
|---------------|----------------|
| BK-Matt Black | NI-Matt Nickel |
| WH-Matt White |                |

• **NUT - SUSPENSION**

20 Ivory White Wood Veneer.  
"Villa El Nido". Marbella, Spain.  
Architects: A-cero Atchitects.

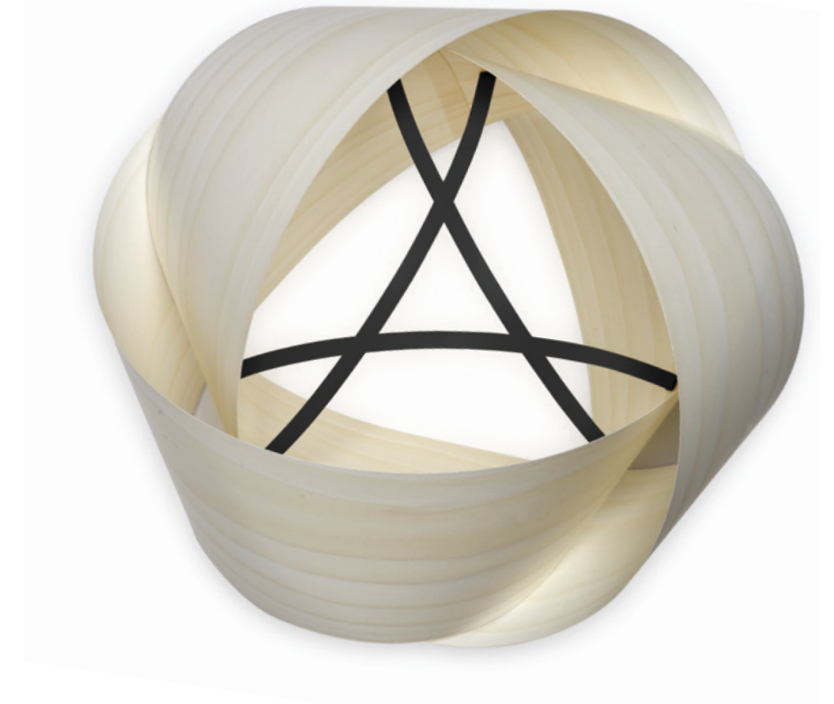

# O

# R

# B

## Orbit

Designed by:  
Miguel Herranz

With its thoughtful air, the ovalesque Orbit light will decorate any wall with quiet self-assurance. Created by Spanish designer Miguel Herranz, Orbit is an unfussy lamp whose shape is handmade by twisting a piece of wood veneer. Two designs are feasible, depending on the direction of torsion—that is how the wood veneer is twisted.

Light from the Orbit is diffused both upwards and downwards via its two apertures and an inner glow radiates outwards, accentuating the beauty of the timber veneer grain. In essence, just as the earth is in orbit around the sun, light is in orbit around the Orbit.

• ORBIT - WALL | 20 Ivory White Wood Veneer. "Caro" Hotel. Valencia, Spain.

# T





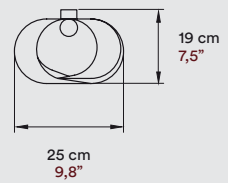
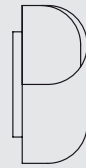
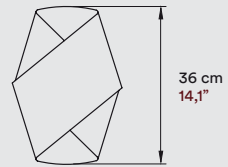

## MATERIALS & COMPONENTS

Wood Veneer Shade

Metal Back Plate

## LIGHT SOURCE

220 - 250V  
Bulb E27



Class I 

120 - 277V  
Bulb E26



## FINISHES

### WOOD VENEER

- |   |                   |   |              |
|---|-------------------|---|--------------|
|  | 20 Ivory White    |  | 26 Red       |
|  | 21 Natural Cherry |  | 28 Blue      |
|  | 22 Natural Beech  |  | 29 Grey      |
|  | 24 Yellow         |  | 33 Pale Rose |
|  | 25 Orange         |  | 34 Sea Blue  |



- **ORBIT - WALL**  
20 Ivory White Wood Veneer.  
"Caro" Hotel. Valencia, Spain.

# OSPLEG

W

L

R



## Pleg

Designed by:  
Yonoh Creative Studio

The Pleg wall light resembles a folded sheet of paper, putting one in mind of a decorative piece of origami. Designed by Yonoh Creative Studio, Pleg is perfect for cosy spaces, bedsides and alcoves, owing to its small size.

Pleg can be installed in four different positions, with light diffused horizontally or vertically from its open sides. At the same time, light emanates warmly through the attractive bent wood veneer. Straightforward, smart and subtle, the Pleg light is modest and charming.

• PLEG - WALL  
20 Ivory White Wood Veneer.  
"Caro" Hotel. Valencia, Spain.



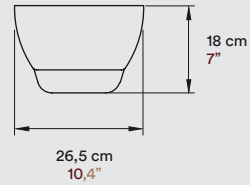

**MATERIALS & COMPONENTS**

Wood Veneer Shade

Acrylic Side Diffuser

Metal Back Plate

**LIGHT SOURCE**

120 - 277V Class I CE

LED Integrated  
Dimmable 0-10V  
or

220 - 250V  
Bulb GX53

120 - 277V cULUS

LED Integrated  
Dimmable 0-10V & TRIAC  
or

120V  
Bulb GX53

**FINISHES**

**WOOD VENEER**

- |   |   |
|---|---|
| <span style="display: inline-block; width: 10px; height: 10px; background-color: white; border: 1px solid black; border-radius: 50%;"></span> 20 Ivory White    | <span style="display: inline-block; width: 10px; height: 10px; background-color: red; border: 1px solid black; border-radius: 50%;"></span> 26 Red            |
| <span style="display: inline-block; width: 10px; height: 10px; background-color: brown; border: 1px solid black; border-radius: 50%;"></span> 21 Natural Cherry | <span style="display: inline-block; width: 10px; height: 10px; background-color: blue; border: 1px solid black; border-radius: 50%;"></span> 28 Blue          |
| <span style="display: inline-block; width: 10px; height: 10px; background-color: yellow; border: 1px solid black; border-radius: 50%;"></span> 22 Natural Beech | <span style="display: inline-block; width: 10px; height: 10px; background-color: grey; border: 1px solid black; border-radius: 50%;"></span> 29 Grey          |
| <span style="display: inline-block; width: 10px; height: 10px; background-color: orange; border: 1px solid black; border-radius: 50%;"></span> 24 Yellow        | <span style="display: inline-block; width: 10px; height: 10px; background-color: pink; border: 1px solid black; border-radius: 50%;"></span> 33 Pale Rose     |
| <span style="display: inline-block; width: 10px; height: 10px; background-color: orange; border: 1px solid black; border-radius: 50%;"></span> 25 Orange        | <span style="display: inline-block; width: 10px; height: 10px; background-color: lightblue; border: 1px solid black; border-radius: 50%;"></span> 34 Sea Blue |

**AWARDS**



Chicago



reddot design award  
Germany



● **PLEG - WALL**  
33 Pale Rose Wood Veneer.  
"La Monella" Jewellers.  
Valencia, Spain.



# POD &

Medium

Designed by:  
Burkhard Dämmer

Kin to the Poppy pendant, Pod is a vertically elongated and ellipse-like orbit of light whose body is made up of a repeated series of wood veneer strips. Different from the Poppy, a small gap between each strip on the Pod allows just a peek at the light within.

The Pod is appreciably unostentatious, having a fresh manner that smiles and illuminates its surroundings with an altruistic sense of cool. It is a pendant that works well discretely or as part of a striking cluster of Pod and Poppy lights.

# POPPY

Small  
Medium

Kin to the Pod pendant, the slightly squat and spherical Poppy lamp is made up of a repeated series of wood veneer strips. Different from the Pod, a larger gap between each strip on the Poppy emits light with a greater luminosity, its mature form sparkling in full bloom.

Compared to the Pod pendant, Poppy is like the mature older sibling, with a fully developed form that lends weight to its mellow disposition. Both the Poppy and Pod lamps work well in unison, able to form impressive cloud-like clusters.



• POD & POPPY - SUSPENSION | 24 Yellow Wood Veneer. "Lucky Apple" Restaurant. Netherlands. Architect: Art2Go Interieurprojecten.



POPPY SMALL

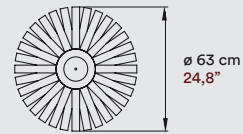
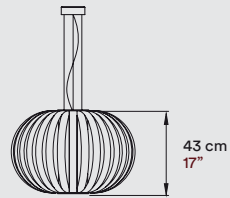

POPPY MEDIUM

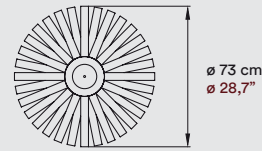
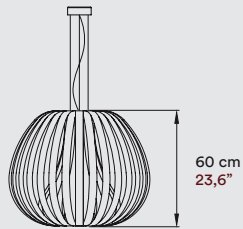

POD MEDIUM

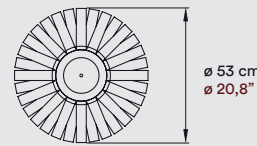
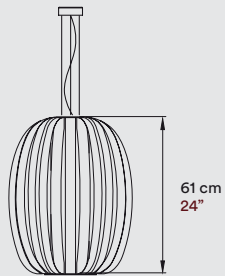

MATERIALS & COMPONENTS

Wood Veneer Shade

Metal Canopy

3 Steel Cables  
2,5 m drop 8 ft drop

Electrical Cable  
2,5 m drop 8 ft drop

LIGHT SOURCE

220 - 250V  
Bulb E27

Class I

120 - 277V  
Bulb E26



FINISHES

WOOD VENEER

- |                   |              |
|-------------------|--------------|
| 20 Ivory White    | 26 Red       |
| 21 Natural Cherry | 28 Blue      |
| 22 Natural Beech  | 29 Grey      |
| 24 Yellow         | 33 Pale Rose |
| 25 Orange         | 34 Sea Blue  |



● POD - MEDIUM SUSPENSION | 20 Ivory White Wood Veneer. "Alameda" Restaurant. Madrid, Spain.

# RAINDROP

## Raindrop

Small  
Medium

Designed by:  
Javier Herrero Studio

Visualise the simple beauty of a stationary raindrop, a small and glistening droplet that instead of falling, remains in a state of suspended animation. While Tina couldn't stand the rain against her window, the Raindrop pendant is a welcome sight.

Javier Herrero imagined and designed the Raindrop pendant, its suspended shade made using strips of wood veneer that contain a glowing ball. Available in small and medium sizes, the Raindrop's form is playful and poised. It is a light that will hang gracefully by itself and is especially pleasing and engaging when arranged in a group formation.

● RAINDROP - MEDIUM SUSPENSION | 20 Ivory White Wood Veneer.





## RAINDROP

## SUSPENSION

JAVIER HERRERO STUDIO

### SMALL



### MEDIUM



## MATERIALS & COMPONENTS

Wood Veneer Shade

Frosted Glass Ball

Metal Canopy

Electrical Cable

2,5 m drop 8 ft drop

Steel Cable

2,5 m drop 8 ft drop

## LIGHT SOURCE

220 - 250V

Bulb G9

Class I

120V

Bulb G9



## FINISHES

### WOOD VENEER

- |                   |              |
|-------------------|--------------|
| 20 Ivory White    | 26 Red       |
| 21 Natural Cherry | 28 Blue      |
| 22 Natural Beech  | 29 Grey      |
| 24 Yellow         | 33 Pale Rose |
| 25 Orange         | 34 Sea Blue  |



- RAINDROP - SMALL SUSPENSION  
21 Natural Cherry  
Wood Veneer.



- RAINDROP - MEDIUM SUSPENSION  
21 Natural Cherry  
Wood Veneer.

# SATURNIA

The Saturnia pendant is reminiscent of Saturn's system of planetary rings. A truly handsome and enchanting light, its form is one that captivates the eye: similar to the way in which we gaze wondrously at stars in the night sky.

Saturnia balances both indirect and direct lighting with aplomb. Its circular wood veneer spreads warm light outwards, while its Plexiglas diffuser provides the perfect direct light necessary for task-oriented jobs and for social or work environments. Saturnia makes a bold statement as a solo light or when suspended in a group of varied sizes.

Small  
Medium  
Large

Designed by:  
Oskar Cerezo



• **SATURNIA**  
**MEDIUM SUSPENSION**  
21 Natural Cherry Wood Veneer. "BNP Paribas Investment Partners".  
Architects: Fokkema and Partners Architecten Amsterdam.



## SMALL

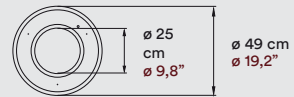
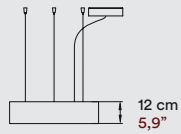

## MEDIUM

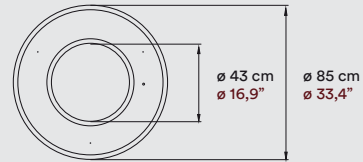
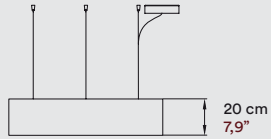

## LARGE

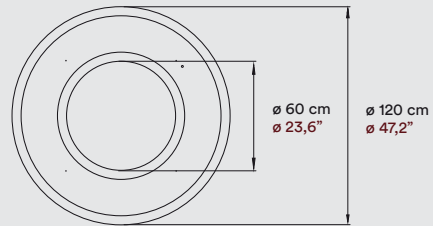
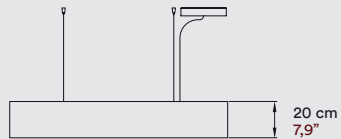

## MATERIALS &amp; COMPONENTS

Wood Veneer Shade

Top &amp; Bottom Acrylic Diffuser

Metal Canopy

3 Steel Cables SMALL &amp; MEDIUM

4 Steel Cables LARGE











2,5 m drop 8 ft drop

Electrical Cable

2,5 m drop 8 ft drop

## FINISHES

## WOOD VENEER

- |   |                   |   |              |
|---|-------------------|---|--------------|
|  | 20 Ivory White    |  | 26 Red       |
|  | 21 Natural Cherry |  | 28 Blue      |
|  | 22 Natural Beech  |  | 29 Grey      |
|  | 24 Yellow         |  | 33 Pale Rose |
|  | 25 Orange         |  | 34 Sea Blue  |

## LIGHT SOURCE

120 - 277V

LED Integrated

Dimmable 0-10V, Bluetooth or DALI

Class I 

120 - 277V

LED Integrated

Dimmable 0-10V &amp; TRIAC



● SATURNIA - LARGE SUSPENSION | 34 SeaBlue Wood Veneer. Boardroom, private company, Netherlands.



# SPIRO

## Spiro

Medium  
Large

Designed by:  
Remedios Simón

Op art (optical art) developed in the 1960s as an artistic style that used geometric shapes to generate optical illusions. With a nod to the genre, designer Remedios Simón created Spiro, a charismatic pendant whose frame contains a mass of irregular wood veneer spirals.

Available in 3 outer shell options (cherrywood or acrylic white or wblack), Spiro is an impressive light with an enchanting aura. Similar to op art, Spiro plays with the physiology and psychology of human perception, its charm utterly irresistible.

### ● SPIRO - LARGE SUSPENSION

Matt White Outer Shell & 22 Natural Beech Wood Veneer.  
"MSK Koch Center" Hospital, NY, USA. Photography: Chris Cooper.





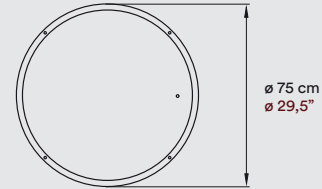
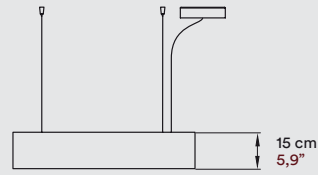
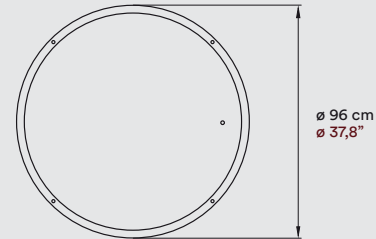
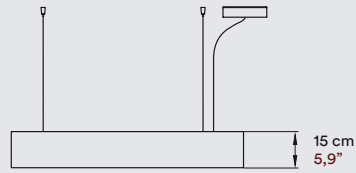

**SPIRO****SUSPENSION****REMEDIOS SIMÓN****MEDIUM****LARGE****MATERIALS & COMPONENTS**

Opaque Wood or Acrylic Outer Shell

Wood Veneer Spirals

Top & Bottom Diffuser

Metal Canopy

4 Steel Cables

2,5 m drop 8 ft drop

Electrical Cable

2,5 m drop 8 ft drop

**LIGHT SOURCE**

120 - 277V

LED Integrated  
Dimmable 0-10V, Bluetooth or DALI

Class I CE

120 - 277V

LED Integrated  
Dimmable 0-10V & TRIAC

cULUS

**FINISHES****WOOD SHELL**

21 Natural Cherry

**ACRYLIC SHELL**

Black

White

**WOOD VENEER SPIRALS WITH WOOD SHELL**

21 Natural Cherry

**WOOD VENEER SPIRALS WITH ACRYLIC SHELL**

20 Ivory White

26 Red

21 Natural Cherry

28 Blue

22 Natural Beech

29 Grey

24 Yellow

33 Pale Rose

25 Orange

34 Sea Blue

**AWARDS**

HD Las Vegas. Product Design Competition. USA

**METAL CANOPY**

BK-Matt Black

WH-Matt White

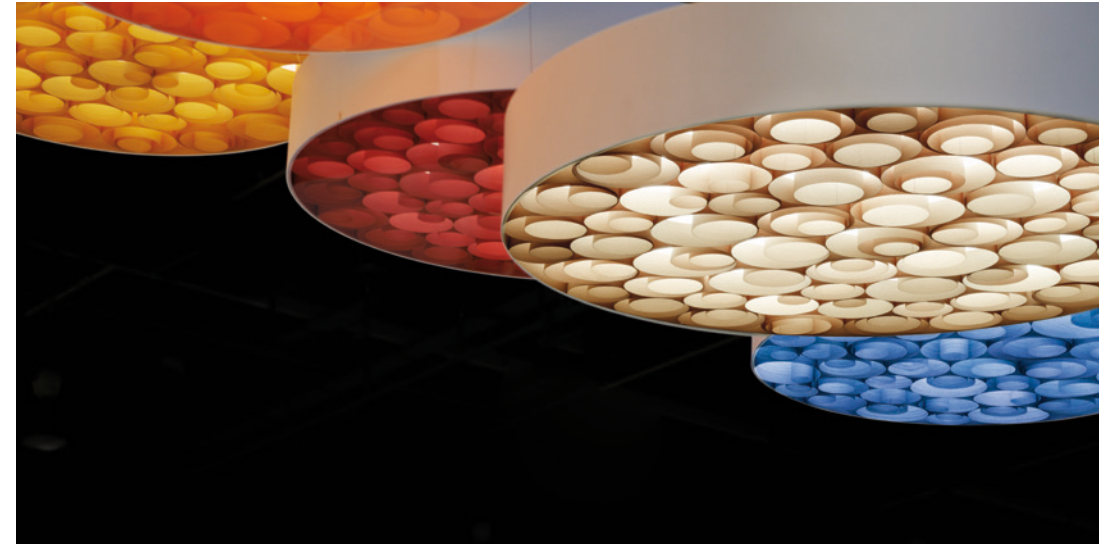
**• SPIRO - LARGE SUSPENSION**

White Outer Shell & 24 Yellow, 25 Orange, 26 Red, 22 Natural Beech & 28 Blue Wood Veneer.

**• SPIRO - LARGE SUSPENSION**

Matt Black Outer Shell & 21 Natural Cherry Wood Veneer.  
"Villa El Nido". Marbella, Spain. Architects: A-cero Architects.



# STITCHES

## Stitches

Bamako  
Tombuctú

Designed by:  
Burojet

Created by Egbert-Jan Lam of Netherlands-based Burojet Design Studio, Stitches is a family of four well-hemmed pendants: Tombuctú and Bamako. Each light is named after a city or town in Mali, West Africa. Mali has a long history as a producer of embroidery, its many skilled artisans found throughout Tombuctú and Bamako-adept at needlework.

The Stitches pendants impart an appealing bohemian air, their warm wood veneer panels embroidered with peeping threads of light. Crafted with passion and precision, Tombuctú and Bamako hint at the simple beauty found in Malian embroidery.

- **STITCHES BAMAKO - SUSPENSION**  
24 Yellow Wood Veneer.  
"Jaleo Disney Springs" Hotel. Washington DC.  
Architect: Juli Capella. Chef: José Andrés.



## BAMAKO

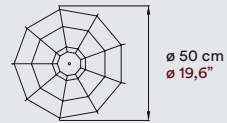
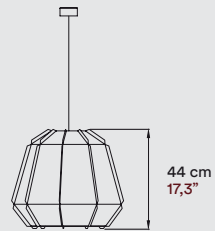

## TOMBUCTÚ

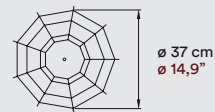
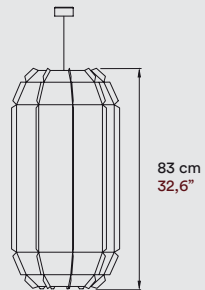

## MATERIALS &amp; COMPONENTS

Wood Veneer Shade

Metal Canopy

**Steel Cable**  
8 ft drop. Only for USA & Canada

**Electrical Cable**  
2,5 m drop 8 ft drop

## LIGHT SOURCE

220 - 250V  
Bulb E27

Class I CE

120 - 277V  
Bulb E26



Chicago

## AWARDS



Germany

## FINISHES

## WOOD VENEER

- |  |  |
|--|--|
|  20 Ivory White |  28 Blue      |
|  24 Yellow      |  29 Grey      |
|  25 Orange      |  33 Pale Rose |
|  26 Red         |  34 Sea Blue  |



● **STITCHES TOMBUCTÚ - SUSPENSION**  
20 Ivory White Wood Veneer. "Palau de Casavells". Girona, Spain.



# S

# W

# R

## Swirl

Small  
Large

Designed by:  
Ray Power

Swirl excites the eye with its eddying and whirling folds, their twisting twirl a sensuous feat. Designed by Ray Power, Swirl is an accomplished pendant, its form thoughtfully considered and sculptured. Power's designs are typically based on geometry and his predilection for creating three-dimensional forms from flat materials (wood veneer). Swirl is no exception, its precise contours brought to life in stereo.

With a soulful character and presence, the Swirl lamp will vibe well with any interior. When a light is striking from every angle, one might expect more than a hint of conceit. And yet Swirl is wholly modest, its beauty inspiring and uplifting.

The Swirl pendant was accorded a Special Mention by the German Design Council.

### ● SWIRL - SMALL SUSPENSION

20 Ivory White Wood Veneer. Apartment. Manresa, Spain. Project: DüeM Estudio. Photography: Davide Pellegrini.

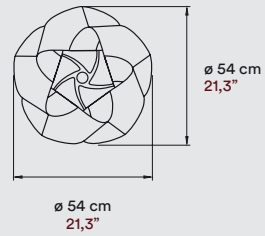
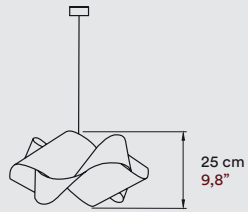
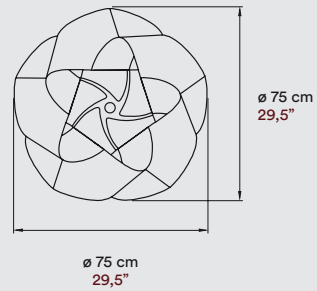
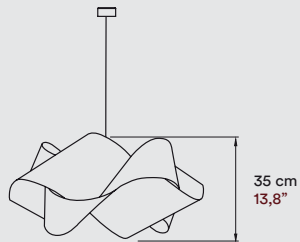

**SWIRL****SUSPENSION****RAY POWER****SMALL****LARGE****MATERIALS & COMPONENTS****Wood Veneer Shade****Metal Tripod & Canopy****Electrical Cable**  
2,5 m drop 8 ft drop**LIGHT SOURCE****220 - 250V**  
Bulb E27 Class I CE**120 - 277V**  
Bulb E26 UL US**AWARDS**

Chicago



Germany

**FINISHES****WOOD VENEER**

- |  |  |
|--|--|
| <span style="display: inline-block; width: 10px; height: 10px; background-color: white; border-radius: 50%;"></span> 20 Ivory White    | <span style="display: inline-block; width: 10px; height: 10px; background-color: red; border-radius: 50%;"></span> 26 Red            |
| <span style="display: inline-block; width: 10px; height: 10px; background-color: brown; border-radius: 50%;"></span> 21 Natural Cherry | <span style="display: inline-block; width: 10px; height: 10px; background-color: blue; border-radius: 50%;"></span> 28 Blue          |
| <span style="display: inline-block; width: 10px; height: 10px; background-color: yellow; border-radius: 50%;"></span> 22 Natural Beech | <span style="display: inline-block; width: 10px; height: 10px; background-color: grey; border-radius: 50%;"></span> 29 Grey          |
| <span style="display: inline-block; width: 10px; height: 10px; background-color: yellow; border-radius: 50%;"></span> 24 Yellow        | <span style="display: inline-block; width: 10px; height: 10px; background-color: pink; border-radius: 50%;"></span> 33 Pale Rose     |
| <span style="display: inline-block; width: 10px; height: 10px; background-color: orange; border-radius: 50%;"></span> 25 Orange        | <span style="display: inline-block; width: 10px; height: 10px; background-color: lightblue; border-radius: 50%;"></span> 34 Sea Blue |

**METAL CANOPY**

- |  |  |
|--|--|
| <span style="display: inline-block; width: 10px; height: 10px; background-color: black; border-radius: 50%;"></span> BK-Matt Black | <span style="display: inline-block; width: 10px; height: 10px; background-color: grey; border-radius: 50%;"></span> NI-Matt Nickel |
| <span style="display: inline-block; width: 10px; height: 10px; background-color: white; border-radius: 50%;"></span> WH-Matt White |  |

- **SWIRL - SMALL SUSPENSION**  
26 Red Wood Veneer.

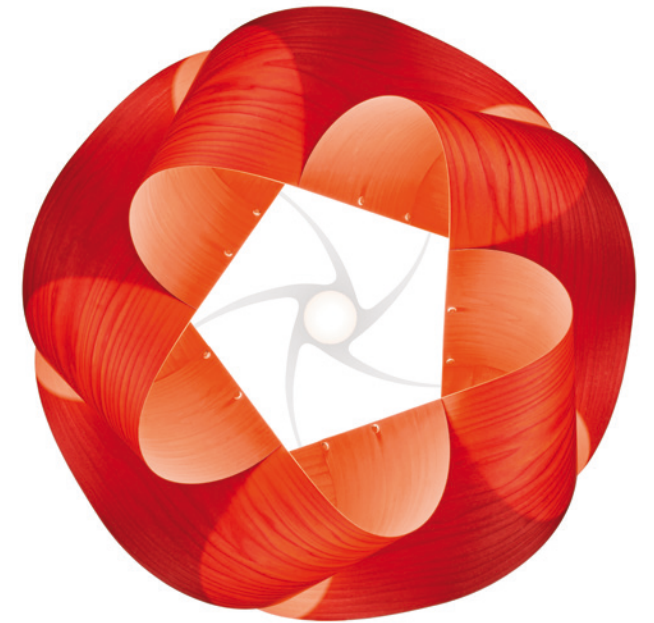

- **SWIRL - SMALL SUSPENSION**  
20 Ivory White Wood Veneer.  
"Mercado Little Spain". NY, USA.  
Architect: Juli Capella.  
Painter: Javier Marical.  
Chef: José Andrés.





## Totem

Totem is a veritable feast for the senses, a light whose proportions enliven a space with dramatic effect. Envisaged by designers Mariví Calvo and Burkhard Dämmer, Totem evolved from the clever amalgamation of Dämmer's Pod and Poppy pendants.

A sublime lighting structure, Totem has the emblematic air of a sacred object, a light whose shape and spirit are reflected in cultures worldwide. Available in three stacked variations, the Totem pendant diffuses warm light through the gaps in its wood veneer strips. As a physical entity, Totem's presence is impressive. Just as important, its spiritual quality is entirely unreserved.

- **TOTEM - SMALL & MEDIUM SUSPENSION**  
20 Ivory White & 28 Blue Wood Veneer.  
"Palau de Casavells". Girona, Spain.

Totem 3  
Totem 4

Designed by:  
Burkhard Dämmer

T  
O  
T  
E

M



## SMALL - TOTEM 3

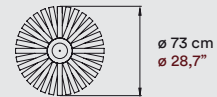
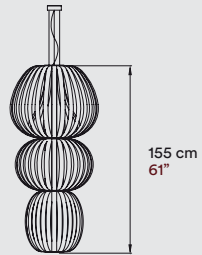

## MEDIUM - TOTEM 4

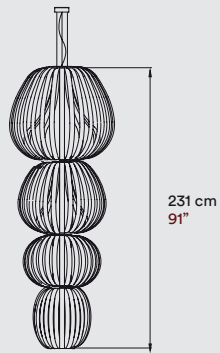

## MATERIALS &amp; COMPONENTS

3 or 4 Wood Veneer Shades

Metal Canopy

3 Steel Cables

2,5 m drop 8 ft drop

Electrical Cable

2,5 m drop 8 ft drop

## LIGHT SOURCE

120 - 277V

LED Integrated  
Dimmable 0-10V or Bluetooth

Class I 







120 - 277V

LED Integrated  
Dimmable 0-10V & TRIAC



## FINISHES

## WOOD VENEER

 20 Ivory White	 26 Red
 21 Natural Cherry	 28 Blue
 22 Natural Beech	 29 Grey
 24 Yellow	 33 Pale Rose
 25 Orange	 34 Sea Blue



● TOTEM - MEDIUM SUSPENSION | 21 Natural Cherry Wood Veneer.  
"Apartment". Netherlands. Architect: Inge Bouman Interieur Architectuur.



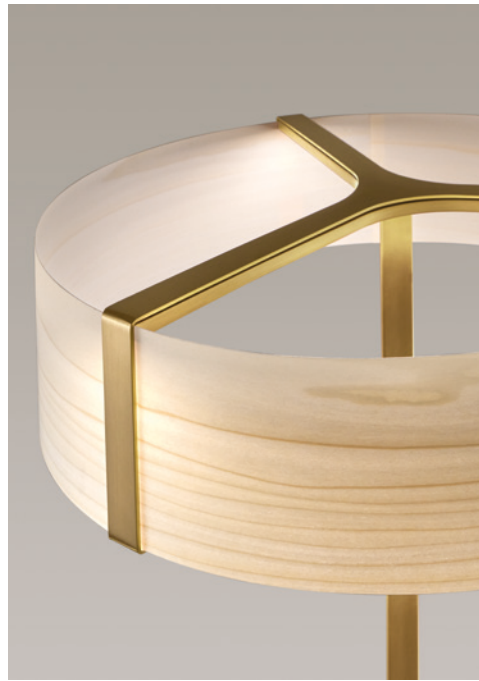

# THESIS

## Thesis

Floor  
Table  
Wall

Designed by:  
Ramón Esteve Estudio

Thesis is a table lamp and a floor lamp. It is a modern lamp whose companionship is close and intimate, casting a warm glow as you toil through the night, and by your side as you read or simply contemplate the day. Designed by Ramón Esteve, the Thesis lamp is well suited to quiet spaces: in a library, private study or cosy corner, its minimal form and clean lines are free from distraction.

In creating Thesis, a modest metallic base holds a wood veneer shade in its three prongs. Each prong contains an LED that diffuses light downwards, while casting a radiance that quietly highlights the natural timber veneer. In profile, it is authoritative and introspective, a quiet light with a smart, introverted personality.

- **THESIS - FLOOR**  
20 White Wood Veneer & Gold Metal Base.



- **THESIS - FLOOR**  
20 White Wood Veneer & Matt Black Metal Base. "Casa en la Huerta". Valencia, Spain. Architect: Ramón Esteve Estudio.

FLOOR

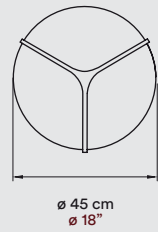
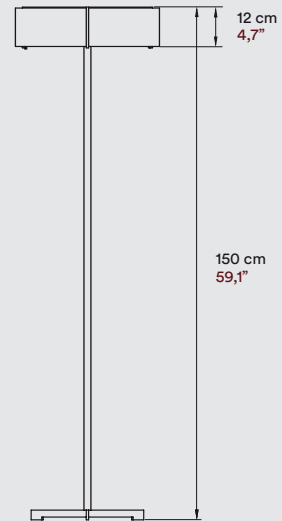

TABLE

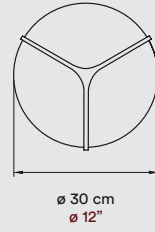
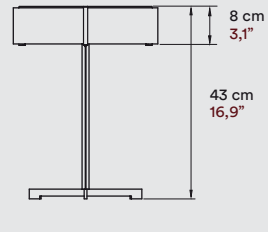

MATERIALS & COMPONENTS

Wood Veneer Shade

Metal Tripod, Stem & Base

Electrical Cable with Dimming Switch

FLOOR 185 cm 53"

TABLE 145 cm 57"

LIGHT SOURCE

230V  
LED Integrated Dimmable

Class II

120V  
LED Integrated Dimmable

FINISHES

FLOOR WOOD VENEER SHADE

20 Ivory White

TABLE WOOD VENEER SHADES

20 Ivory White 22 Natural Beech

21 Natural Cherry 29 Grey

METAL

IV-Matt Ivory NI-Matt Nickel

BK-Matt Black GD-Gold



● **THESIS - TABLE**  
20 Ivory White Wood Veneer & Matt Black Metal Base.

● **THESIS - TABLE**  
29 Grey Wood Veneer & Matt Black Metal Base.  
Photo: 4000k. "Casa en la Huerta". Valencia, Spain.  
Architect: Ramón Esteve Estudio.





• THESIS - FLOOR & TABLE | 20 White Wood Veneer & Matt Ivory Metal Base. "Casa en la Huerta". Valencia, Spain. Architect: Ramón Esteve Estudio.



SWING MECHANISM

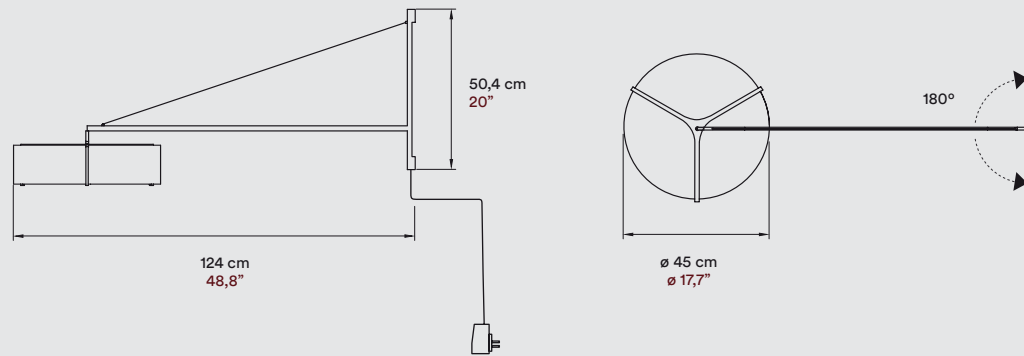

MATERIALS & COMPONENTS

Wood Veneer Shade

Metal Tripod & Structure

Electrical Cable with Dimming Switch  
250 cm 98,4"

LIGHT SOURCE

230V  
LED Integrated Dimmable

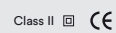

120V  
LED Integrated Dimmable



FINISHES

WOOD VENEER

- 20 Ivory White
- 22 Natural Beech
- 21 Natural Cherry
- 29 Grey

METAL

- IV-Matt Ivory
- NI-Matt Nickel
- BK-Matt Black
- GD-Gold



● **THESIS - WALL**  
29 Grey Wood Veneer & Matt Black Metal Structure. Photo: 4000k.  
"Bouet" Restaurant. Valencia, Spain. Architect: Ramón Esteve Estudio.





## X-Club

Suspension  
Wall  
Ceiling

Hit the spot with the X-Club light designed by Burkhard Dämmer. With its curvy form, the X-Club emanates light with a sensual quality, akin to a three-dimensional kiss.

A wall, ceiling or suspension light, the X-Club confidently marks the spot wherever it is placed. Suited to numerous environments and contexts, from residential to retail, it is an especially impactful design when placed in clusters or rows. Light from the X-Club is both ambient and direct, with its wood veneer striking a prepossessing pose when illuminated.

- **X-CLUB - SUSPENSION**  
24 Yellow & 26 Red Wood Veneer. Pharmacy, Switzerland.



# CLUB

Designed by:  
Burkhard Dämmer

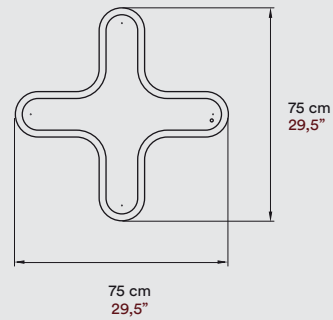
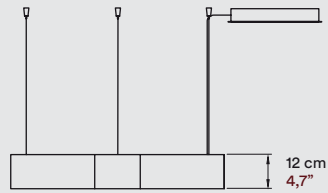

## MATERIALS & COMPONENTS

### Wood Veneer Shade

### Top & Bottom Acrylic Diffuser

### Metal Canopy

### 4 Steel Cables

2,5 m drop 8 ft drop

### Electrical Cable

2,5 m drop 8 ft drop

## LIGHT SOURCE

### 120 - 277V

LED Integrated  
Dimmable 0-10V, Bluetooth or DALI

Class I

### 120 - 277V

LED Integrated  
Dimmable 0-10V & TRIAC

## FINISHES

### WOOD VENEER

20 Ivory White	26 Red
21 Natural Cherry	28 Blue
22 Natural Beech	29 Grey
24 Yellow	33 Pale Rose
25 Orange	34 Sea Blue

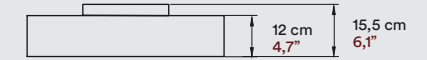
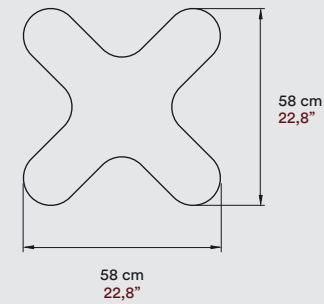

## MATERIALS & COMPONENTS

### Wood Veneer Shade

### Frontal Acrylic Diffuser

### Metal Back plate

## LIGHT SOURCE

### 120 - 277V

LED Integrated  
Dimmable 0-10V, Bluetooth or DALI

Class I

### 120 - 277V

LED Integrated  
Dimmable 0-10V & TRIAC

## FINISHES

### WOOD VENEER

20 Ivory White	26 Red
21 Natural Cherry	28 Blue
22 Natural Beech	29 Grey
24 Yellow	33 Pale Rose
25 Orange	34 Sea Blue



LIFE  
SIZE



# SMELLY FANT

## Smelly Fant

Designed by:  
Isidro Ferrer & LZF Lab

Smelly Fant is the other Funny Farm animal we chose to convert into a light sculpture. Like all elephants, it has big ears, a trunk, even its own legs, and a body standing more than a meter and a half tall. To turn Isidro Ferrer's vision into a large-scale lamp, LZF has again drawn on the experience of the craftsman Manolo Martin.

Just as he did with Fish, Manolo used the "vareta" technique to shape the three spheres which constitute the body and the head of Elephant. Its luminous heart, at the centre of the sculpture, is diffused through a natural wood veneer internal lining.

- **SMELLY FANT - FLOOR**  
20 Ivory White Wood Veneer.  
"Palau de Casavells". Girona, Spain.





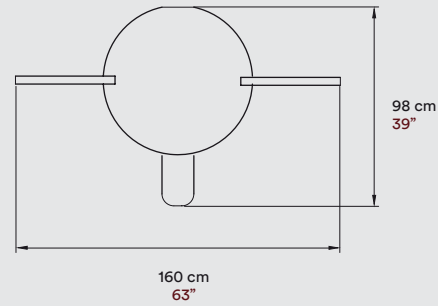
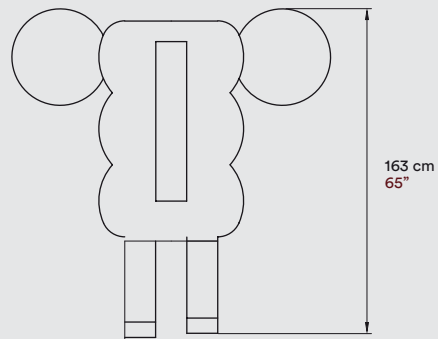

## MATERIALS & COMPONENTS

Oak & Birch Wood

Wood Veneer Diffuser

Electrical Cable with Dimming Switch  
200 cm 78,7"

## LIGHT SOURCE

LED Integrated

Class II 

LED Integrated

## FINISHES

### WOOD VENEER

 20 Ivory White

## AWARDS



Chicago



- **SMELLY FANT - FLOOR** | LZF "Dreams Book".  
20 Ivory White Wood Veneer.  
"Palau de Casavells". Girona, Spain.

# FISH

## The Walking Fish

Fish is modelled on one of the original pieces by Isidro Ferrer, a friendly fish with legs which has become one of the first large-scale light sculptures within the Funny Farm project. The carefully studied layout produces a captivating effect.

Designed by:  
Isidro Ferrer & LZF Lab

- **THE WALKING FISH - FLOOR**  
20 Ivory White Wood Veneer. "Palau de Casavells". Girona, Spain.





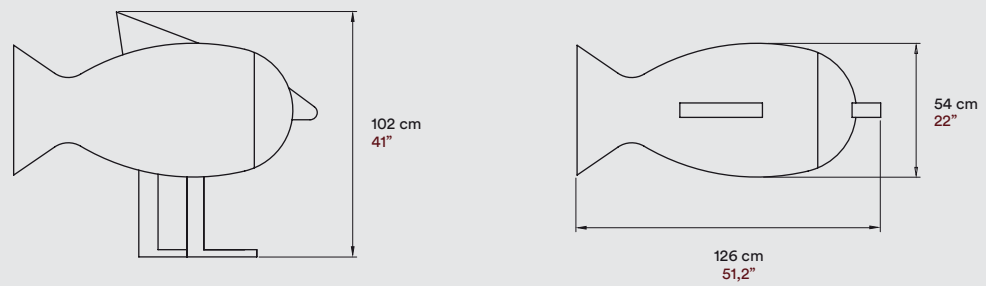

**MATERIALS & COMPONENTS**

Oak & Birch Wood

Wood Veneer Diffuser

Electrical Cable with Dimming Switch  
200 cm 78,7"

**LIGHT SOURCE**

LED Integrated

Class II

LED Integrated

**FINISHES**

WOOD VENEER

20 Ivory White



- **THE WALKING FISH**  
20 Ivory White Wood Veneer.

# BIG BIRD

## Big Bird

Designed by:  
Isidro Ferrer & LZF Lab

As a new member of LZF's Life-Size family, Big Bird joins the happy adventures of Smelly Fant, Fish and Koi. Hovering vertically with fluttering wings, Big Bird has the agile appearance of a gentle hummingbird.

Created by the illustrator and designer Isidro Ferrer and built using a traditional craft technique called vareta, Big Bird is a masterly feat of wood craftsmanship. While light radiates from Big Bird's wooden plumage, a glass globe hangs from its beak, like a ball of glowing nectar.

With Big Bird, LZF is once again dreaming big, re-engineering the concept of what a lamp can be, in both shape and scale.

### • BIG BIRD VERTICAL - SUSPENSION

Crafted Elm and Birchwood exterior, Interior Tulip Wood diffuser in 20 Ivory White.





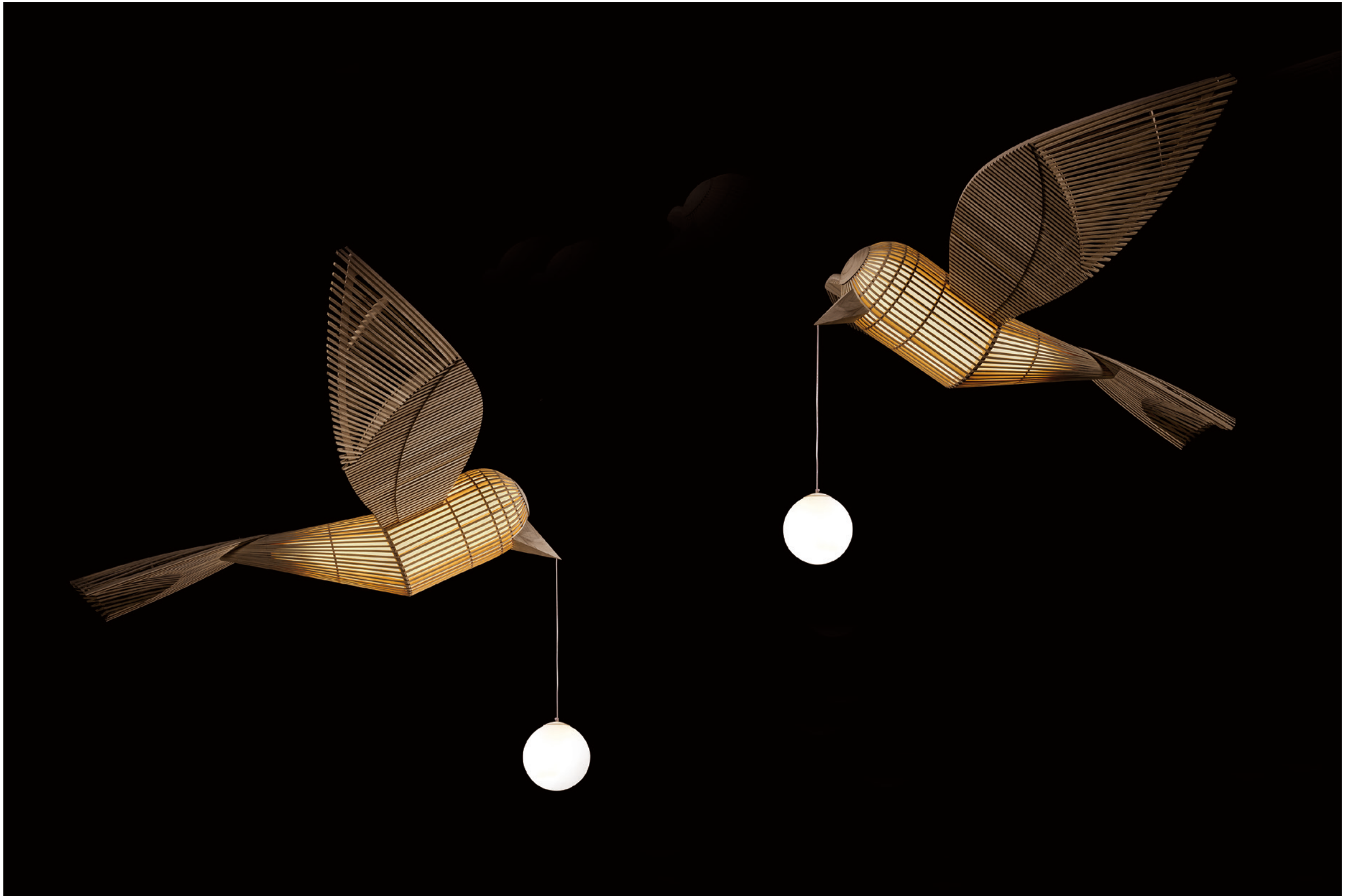

• **BIG BIRD HORIZONTAL - SUSPENSION**  
Crafted Elm and Birchwood exterior, Interior Tulip Wood diffuser in 20 Ivory White.



• **BIG BIRD HORIZONTAL - SUSPENSION** | Crafted Elm and Birchwood exterior, Interior Tulip Wood diffuser in 20 Ivory White.

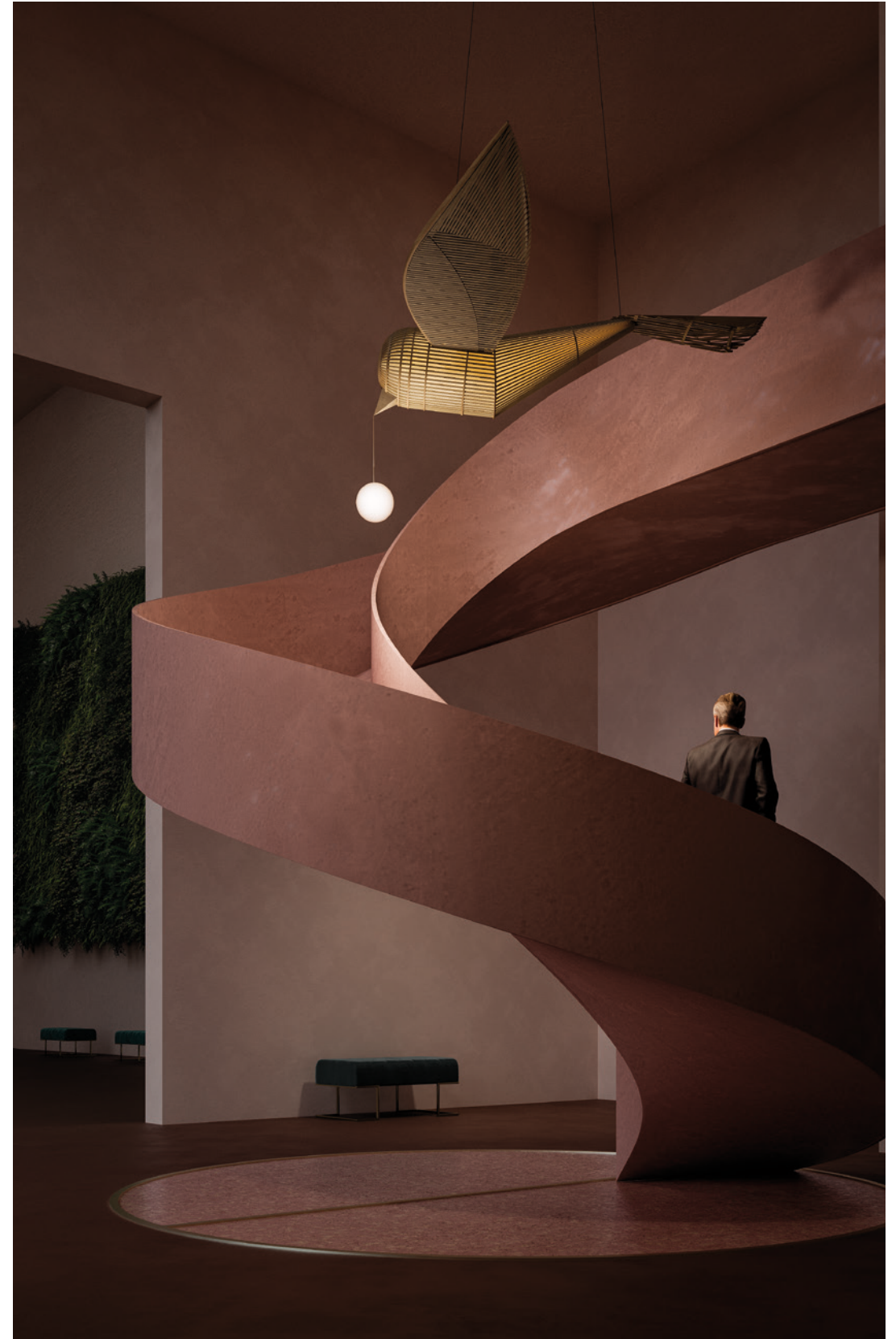



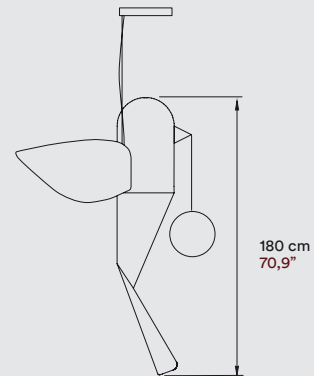
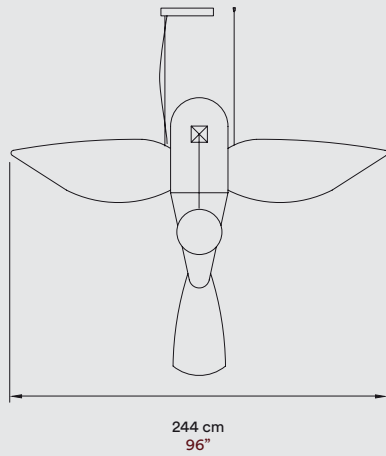

## MATERIALS & COMPONENTS

Oak & Birch Wood

Wood Veneer Diffuser

Frosted Glass Ball

Metal Canopy

**2 Steel Cables**  
5 m drop 16,5 ft drop

**Electrical Cable**  
5 m drop 16,5 ft drop

## FINISHES

WOOD VENEER

● 20 Ivory White

## LIGHT SOURCE

**120 - 277V**  
LED Integrated  
Dimmable 0-10V, Bluetooth or DALI &  
Bulb E27

Class I

**120 - 277V**  
LED Integrated Dimmable &  
Bulb E26

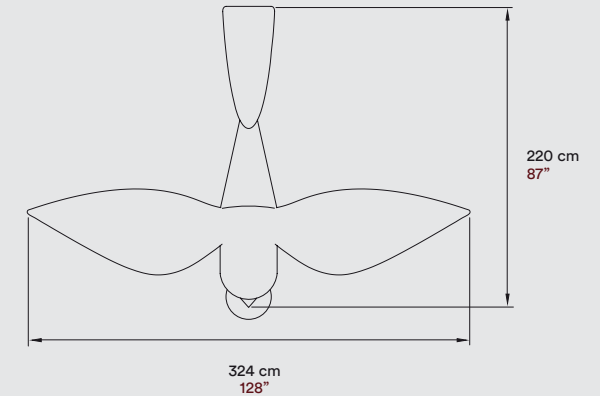
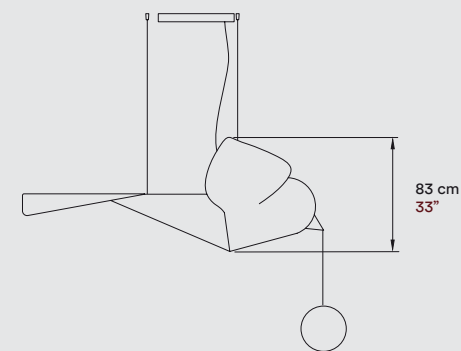

## MATERIALS & COMPONENTS

Oak & Birch Wood

Wood Veneer Diffuser

Frosted Glass Ball

Metal Canopy

**3 Steel Cables**  
5 m drop 16,5 ft drop

**Electrical Cable**  
5 m drop 16,5 ft drop

## FINISHES

WOOD VENEER

● 20 Ivory White

## LIGHT SOURCE

**120 - 277V**  
LED Integrated  
Dimmable 0-10V, Bluetooth or DALI &  
Bulb E27

Class I

**120 - 277V**  
LED Integrated Dimmable &  
Bulb E26

# KOI

## Koi

Designed by:  
Inocuo The sign & LZF Lab

Part pendant, part sculpture, Koi is a dramatic and decorative light that appears as a surreal wood creature. Koi has an ethereal beauty: engendering a considerable sense of wonderment, its animated form captivates the eye. Cutting an imposing figure, it offers the perfect lighting climax.



• KOI - SUSPENSION | 20 Ivory White Wood Veneer. LZF "Dreams Book".



KOI

LIFE SIZE - SUSPENSION

ISIDRO FERRER

SMALL - KOGOI



LARGE - KOI

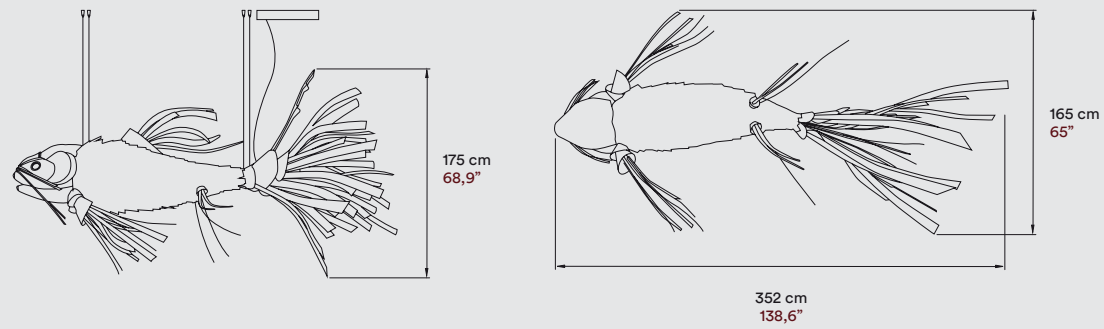

MATERIALS & COMPONENTS

Oak & Birch Wood

Wood Veneer Diffuser

Metal Canopy

4 Steel Cables

5 m drop 16,5 ft drop

Electrical Cable

5 m drop 16,5 ft drop

FINISHES

WOOD VENEER

● 20 Ivory White

● 22 Natural Beech

LIGHT SOURCE

120 - 277V

LED Integrated

Dimmable 0-10V, Bluetooth or DALI

Class I



120 - 277V

LED Integrated

Dimmable 0-10V



AWARDS

Chicago



● KOI - SUSPENSION | 22 Natural Beech Wood Veneer. "Kohakinho" Restaurant. Switzerland. Architect: Bruner Huber. Photography: FTFOTO.

---

# FINISHES



# NATURAL TIMBER VENEER



The dramatic effect of light passing through the wood veneer is the essence and hallmark of LZF. This important feature would not be possible without the application of our patented process in treating the raw natural veneer: the Timberlite® system.

This system, the result of LZF's research & development work, allows us to work with an extremely flexible, yet very resistant veneer, which can take on many shapes without breaking. In addition to all our veneers being FSC certified, thanks to the treatment, the wood used to fabricate our lamps maintains its natural qualities, adopting different nuances and hues over time.

## SOURCE LIGHT TEMPERATURE

Choose your light temperature carefully, wood veneer colour can change radically depending on the colour temperature you use.

Recommended temperature LED for coloured LZF shades:

20- Ivory White (3000k-6400k)

21-Cherry, 22-Beech, 28-Blue, 29-Grey and 34 Sea Blue (4000k)

24-Yellow, 25-Orange, 26-Red and 33 Pale Rose (2700k-4000k)

21 Natural Cherry Off



21 Natural Cherry 4000k

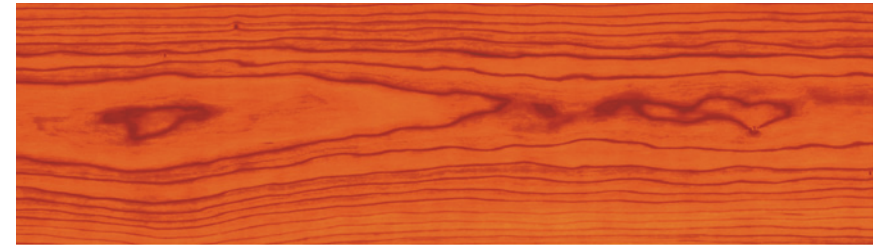

21 Natural Cherry 3000k

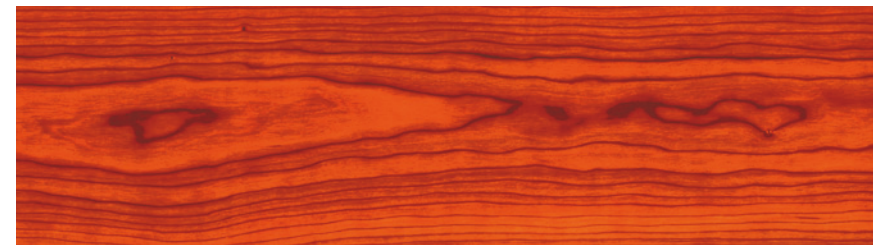

21 Natural Cherry 2700k

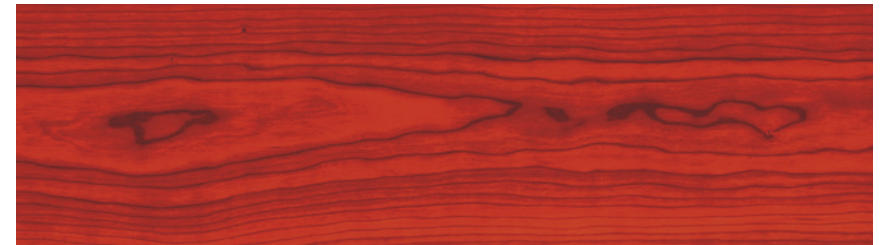

# WOOD SHADE FINISHES

20.  
Ivory White  
Off



20.  
Ivory White  
On



21.  
Natural  
Cherry  
Off



21.  
Natural  
Cherry  
On

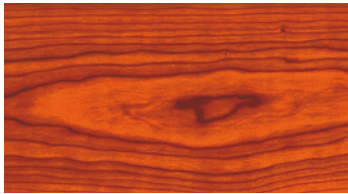

22.  
Natural  
Beech  
Off



22.  
Natural  
Beech  
On



24.  
Yellow  
Off



24.  
Yellow  
On

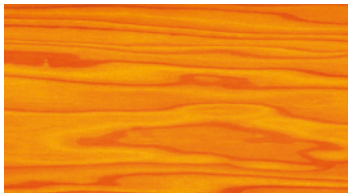

25.  
Orange  
Off



25.  
Orange  
On

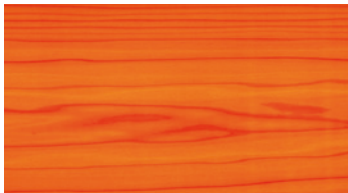

26.  
Red  
Off



26.  
Red  
On



28.  
Blue  
Off



28.  
Blue  
On

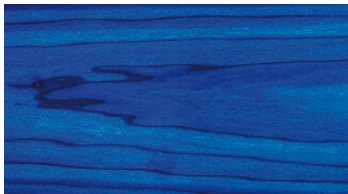

29.  
Grey  
Off



29.  
Grey  
On



33.  
Pale Rose  
Off



33.  
Pale Rose  
On



34.  
Sea Blue  
Off

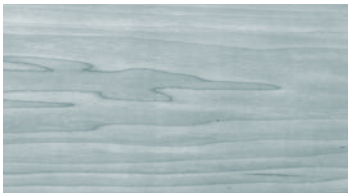

34.  
Sea Blue  
On

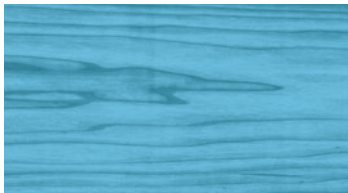

Please only use these reproductions as a guide.  
Use LZF wood swatches to see the spectacular real effect of the illuminated veneers.



# METAL FINISHES



For too many years things have been simply black and white, but life is made up of many shades and we have been wanting to create a more generous array of skin colours for our lights for quite sometime. This year we have wanted to offer you the choice of not just picking your shade colour but also the colour of the metallic finish that accompanies it. Matt tones or coloured reflections in satin nickel finishes provide a whole new range of choice when selecting your lamp.

BK  
Matt Black



NI  
Matt Nickel



GD  
Gold



IV  
Matt Ivory

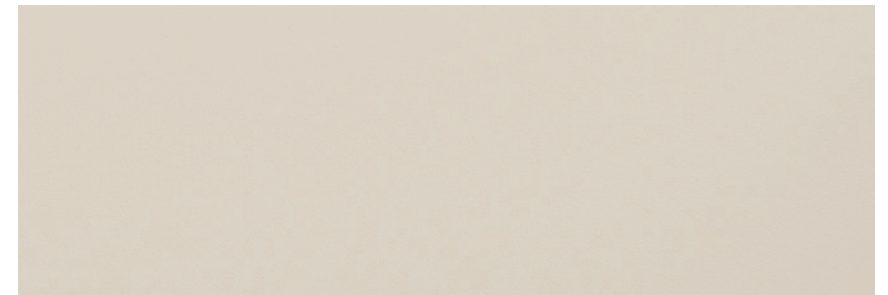

# DESIGNERS

## ISIDRO FERRER

Big Bird  
Smelly Fant  
The Walking Fish



## LUIS ESLAVA STUDIO

Agatha



## RAMÓN ESTEVE ESTUDIO

Black Note  
Thesis



## MUT DESIGN

Lens  
Tomo



## OSKAR CEREZO

Carambola  
Saturnia



## JAVIER HERRERO STUDIO

Raindrop



## MARIVÍ CALVO

Candelabro  
Cosmos  
Gea  
Guijarro  
Oh!Line



## RAY POWER

Air  
Escape  
Hi-Collar  
Link  
Lola  
New Wave  
Nut  
Swirl



## MIGUEL HERRANZ

MiniMikado  
Orbit



## RQR STUDIO

Domo



## YONOH CREATIVE STUDIO

Banga  
Chou  
Mini Chou  
Pleg



## BURKHARD DÄMMER

Cuad  
Dandelion  
I-Club  
I-Line  
Oh!Line  
Pod & Poppy  
Totem  
X-Club



## REMEDIOS SIMÓN

Spiro



## BUROJET

Stitches





---

# CREDITS

---

**Project Director**

Mariví Calvo

---

**Graphic Design**

Lo Siento

---

**Photo Art Direction**

Mariví Calvo

---

**Lzf Graphic Design**

Miriam Castellano

---

**Writer**

Gerard McGuickin

---

**Printed By**

Logik Graphics, 2021

---

**Photographers**

Santiago Relanzón  
Ángel Segura  
Klunderbie  
Jara Varela  
Cualiti  
Maria Mira

---

**All our thanks to**

Pablo Gironés  
Ramón Esteve

---

©Luziferlamps, S.L. Valencia, Spain. 2021. All rights reserved.



In the USA, LZF is exclusively distributed by:

IMPORT&ENT

IMPORT&ENT LLC. 2750 NW 84th Ave. Doral, FL 33122. T (404) 382-9023



